



**PDHonline Course C482 (5 PDH)**

---

**FHWA Bridge Inspector's Manual  
Sections 8.1-2 Steel Superstructures**

*Instructor: Mark P. Rossow, Ph.D, PE Retired*

**2012**

**PDH Online | PDH Center**

5272 Meadow Estates Drive  
Fairfax, VA 22030-6658  
Phone & Fax: 703-988-0088  
[www.PDHonline.org](http://www.PDHonline.org)  
[www.PDHcenter.com](http://www.PDHcenter.com)

An Approved Continuing Education Provider

# Table of Contents

---

Chapter 8	.....	
Inspection and Evaluation of Common Steel Superstructures		
8.1	Fatigue and Fracture in Steel Bridges.....	8.1.1
8.1.1	Introduction .....	8.1.1
	Fracture Critical Member.....	8.1.2
	Fatigue .....	8.1.2
	Reviewing Member Forces .....	8.1.2
	Redundancy.....	8.1.3
	Load Path Redundancy.....	8.1.3
	Structural Redundancy .....	8.1.4
	Internal Redundancy.....	8.1.5
	Nonredundant Configuration.....	8.1.6
8.1.2	Failure Mechanics.....	8.1.7
	Crack Initiation .....	8.1.7
	Crack Propagation.....	8.1.8
	Fracture .....	8.1.8
	Fatigue Life .....	8.1.8
	Types of Fractures.....	8.1.8
	Factors that Determine Fracture Behavior .....	8.1.9
	Fracture Toughness .....	8.1.10
8.1.3	Factors Affecting Fatigue Crack Initiation .....	8.1.10
	Welds .....	8.1.10
	Material Flaws.....	8.1.15
	Fabrication Flaws.....	8.1.16
	Transportation and Erection Flaws .....	8.1.21
	In-Service Flaws .....	8.1.22
8.1.4	Factors Affecting Fatigue Crack Propagation .....	8.1.22
	Stress Range.....	8.1.23
	Number of Cycles .....	8.1.23

SECTION 8: Inspection and Evaluation of Common Steel Superstructures  
TOPIC 8.1: Fatigue and Fracture in Steel Bridges

	Type of Details.....	8.1.23
	Flange Crack Failure Process .....	8.1.25
	Web Crack Failure Process .....	8.1.29
8.1.5	AASHTO Detail Categories for Load-Induced Fatigue .....	8.1.31
	Category A .....	8.1.31
	Category B .....	8.1.32
	Category B'.....	8.1.32
	Category C and C' .....	8.1.32
	Category D .....	8.1.32
	Category E and E'.....	8.1.33
8.1.6	Fracture Critical Bridge Types .....	8.1.41
8.1.7	Fracture Criticality.....	8.1.41
	Details and Defects .....	8.1.42
8.1.8	Inspection Procedures and Locations .....	8.1.44
	Procedures.....	8.1.44
	Visual.....	8.1.44
	Physical.....	8.1.44
	Advanced Inspection Techniques .....	8.1.45
	Inspection of Details.....	8.1.45
	Recordkeeping and Documentation.....	8.1.45
	Recommendations .....	8.1.46
	Locations.....	8.1.46
	Welded Details .....	8.1.46
	Riveted and Bolted Details.....	8.1.48
	Copes .....	8.1.49
	Flange Terminations .....	8.1.50
	End Restraints.....	8.1.50
	Out-of-Plane Distortion .....	8.1.51
	Cracks Perpendicular to Primary Stress .....	8.1.54
	Cracks Parallel to Primary Stress .....	8.1.54
	Corrosion .....	8.1.55
8.1.9	Evaluation .....	8.1.55
	NBI Rating Guidelines and Element Level Condition State Assessment .....	8.1.55

# Section 8

## Inspection and Evaluation of Common Steel Superstructures

### Topic 8.1 Fatigue and Fracture in Steel Bridges

#### 8.1.1

##### Introduction

Since the 1960's, many steel bridges have developed fatigue induced cracks. Although these localized failures have been extensive, only a few U.S. bridges have actually collapsed as a result of steel fatigue fractures.

The first collapse was the Silver Bridge over the Ohio River at Point Pleasant, West Virginia on December 15, 1967. This structure was an eyebar chain suspension bridge with a 213 m (700-foot) main span that collapsed without warning and forty-six people died (see Figure 8.1.1). The collapse was due to stress corrosion and corrosion fatigue that allowed a minute crack, formed during casting of an eye-bar, to grow. The two contributing factors, over the years continued to weaken the eye-bar. Stress corrosion cracking is the formation of brittle cracks in a normally sound material through the simultaneous action of a tensile stress and a corrosive environment. Corrosion fatigue occurs as a result of the combined action of a cyclic stress and a corrosive environment. The bridge's eye-bars were linked together in pairs like a chain. A huge pin passed through the eye and linked each piece to the next. The heat-treated carbon steel eye-bar broke, placing undue stress on the other members of the bridge. The remaining steel frame buckled and fell due to the newly concentrated stresses.



Figure 8.1.1 Silver Bridge Collapse

The second collapse occurred on June 28, 1983, when a suspended two-girder span carrying I-95 across the Mianus River in Greenwich, Connecticut failed (see Figure 8.1.2).



**Figure 8.1.2** Mianus River Bridge Failure

The above catastrophes were a result of fatigue cracking to the point of failure of a fracture critical member. For bridge inspectors, understanding the causes of the common member failure modes is of utmost importance. This understanding permits the inspector to use more time evaluating the trouble areas of a bridge and less time on the others.

When inspecting steel bridges, the inspector must be able to identify a fracture critical member by sight or based on previous reports and drawings. The National Bridge Inspection Standards (NBIS) require that all fracture critical members on a bridge be identified, and the inspection procedures listed prior to an inspection.

**Fracture Critical Member**

A fracture critical member (FCM) is a steel member in tension, or with a tension element, whose failure would probably cause a portion of or the entire bridge to collapse. Bridges that contain fracture critical members are fracture critical bridges.

**Fatigue**

Fatigue is the tendency of a member to fail at a stress level below its yield stress when subject to cyclical loading.

Fatigue is the primary cause of failure in fracture critical members. Describing the process by which a member fails when subjected to fatigue is called failure mechanics.

**Reviewing Member Forces**

For a bridge member to be classified as fracture critical, it must meet two criteria. The first criterion deals with the forces in the member. Members that are in tension or members that have fibers or elements that are in tension meet the first criterion. The five types of member forces are discussed in Topic P.2.3 and

include:

- Axial tension – Acts along the longitudinal axis of a member and tends to “pull” the member apart
- Axial compression – Acts along the longitudinal axis of a member and tends to “push” the member together
- Shear – Equal but opposite transverse forces which tend to slide one section of a member past an adjacent section producing diagonal tension oriented 45 degrees to the longitudinal axis
- Flexure – Caused by moment commonly developed by the transverse loading of a member producing both tension and compression
- Torsion – Results from externally applied moments that tend to twist or rotate the member about its longitudinal axis producing diagonal tension present on all surfaces of the member

## **Redundancy**

The second criterion for a bridge member to be classified as fracture critical is that its failure must cause a total or partial collapse of the structure. Therefore, recognition and identification of a bridge’s degree of redundancy is crucial.

Redundancy is defined as a structural condition where there are more elements of support than are necessary for stability.

Redundancy means that should a member or element fail, the load previously carried by the failed member will be redistributed to other members or elements. These other members have the capacity to temporarily carry additional load, and collapse of the structure may be avoided. On nonredundant structures, the redistribution of load may cause additional members to also fail, resulting in a partial or total collapse of the structure.

There are three basic types of redundancy in bridge design:

- Load path redundancy
- Structural redundancy
- Internal redundancy

### **Load Path Redundancy**

Bridge designs that have three or more main load-carrying members or load paths between supports are considered load path redundant. If one member were to fail, the bridge load would likely be redistributed to the other members, and bridge failure may not occur. An example of load path redundancy is a multi-girder bridge (see Figure 8.1.3).

Some agencies require that a bridge have four or more main load carrying members to be considered load path redundant. Definitive determination of load path redundancy requires structural analysis with members eliminated in turn to determine resulting stresses in the remaining members.



**Figure 8.1.3** Load Path Redundant Multi-Girder Bridge

### **Structural Redundancy**

Bridge designs which provide continuity of load path from span to span are referred to as structurally redundant. Continuous span arrangements consisting of three or more spans are considered structurally redundant (see Figure 8.1.4). In the event of an interior member failure, loading from that span can be redistributed to the adjacent spans, and bridge failure may not occur.



**Figure 8.1.4** Structurally Redundant Continuous Span Bridge

The degree of structural redundancy can be determined through computer programs which model element failure. Some continuous truss bridges have structural redundancy, but this can only be determined through structural analysis.

Continuous spans are structurally redundant except for the end spans, where the development of a fracture would effectively cause two hinges, one at the abutment and one at the fracture itself. This situation would lead to structural instability.

### Internal Redundancy

Internal or member redundancy exists when a bridge member contains three or more elements that are mechanically fastened together so that multiple independent load paths are formed. Failure of one member element might not cause total failure of the member. Examples of internally redundant members are shown in Figures 8.1.5 and 8.1.6.

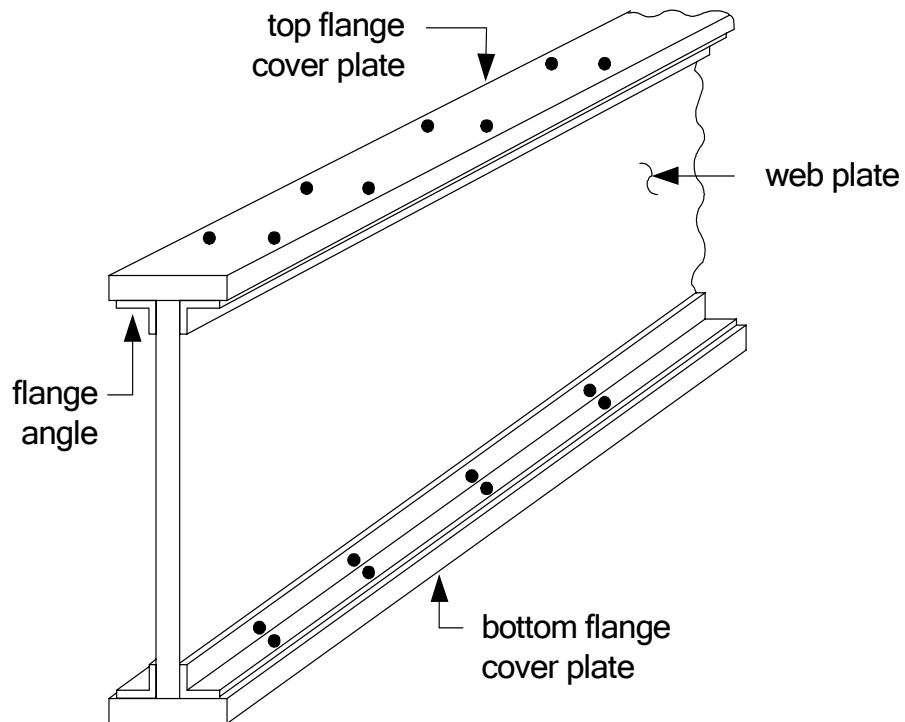

**Figure 8.1.5** Internally Redundant Riveted I-Beam



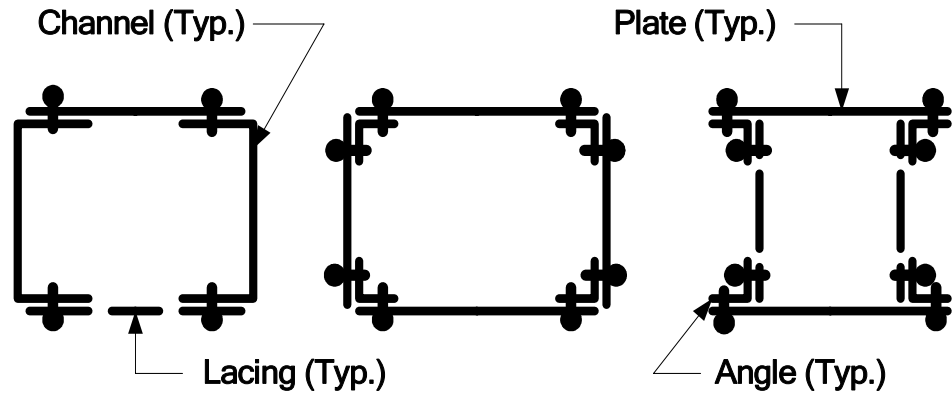

**Figure 8.1.6** Internally Redundant Riveted Box Shapes

Internal redundancy of a member can be decreased or eliminated by repairs that involve welding. The welds provide paths for cracks to travel from one element to another (see Figure 8.1.7).



**Figure 8.1.7** Patch Plate on Girder Web along Flange Angle

### Non-redundant Configuration

Bridge inspectors are concerned primarily with load path redundancy. The inspector should neglect structural and internal redundancy and classify all bridges with less than three load paths as nonredundant (see Figure 8.1.8). Nonredundant bridge configurations in tension contain fracture critical members.

*AASHTO Standard Specifications for Highway Bridges*, 17th Edition, Section 10.3.1 states that main load carrying components subjected to tensile stresses may be considered nonredundant load path members if failure of a single element could cause collapse.

*AASHTO LRFD Bridge Design Specifications*, 3<sup>rd</sup> Edition, with 2005 Interim Revisions, Section 1.2, defines multiple load path structures as structures capable of supporting specified loads following loss of a main load-carrying component or connection. If a structure cannot support the specified loads following loss of a main load carrying member, the consequence is “collapse” as defined in the *AASHTO LRFD Specifications*. Section 1.2 defines collapse as a major change in geometry of the bridge rendering it unfit for use.

*AASHTO LRFD Specifications*, Section 1.3.4, discusses redundancy. Main elements and components whose failure is expected to cause collapse of the bridge are designated as failure-critical and the associated structural system is considered nonredundant. Failure-critical members in tension may be designated as fracture-critical. Those elements and components whose failure is not expected to cause collapse of the bridge are nonfailure-critical and the associated structural system is considered redundant.



**Figure 8.1.8** Nonredundant Two-Girder

## 8.1.2

### **Failure Mechanics**

Failure mechanics involves describing the process by which a member fails when subjected to fatigue.

The fatigue failure process of a member consists of three stages:

- Crack initiation
- Crack propagation
- Fracture

### **Crack Initiation**

Cracks most commonly initiate from points of stress concentrations in structural details. The most critical conditions for crack initiation at structural details are those combining:

- High stress concentrations due to flaws
- High stress concentrations due to connection details
- High stress concentrations due to out-of-plane distortions

### Crack Propagation

Once a fatigue crack has initiated, applied cyclic stresses cause propagation, or growth, of a crack across the section of the member until it reaches a critical size, at which time the member may fracture.

### Fracture

Once a crack has initiated and propagated to a critical size, the member fractures. Fracture of a member is the separation of the member into two parts. The fracture of a critical member may cause a total or partial bridge collapse.

### Fatigue Life

The number of cycles required to initiate a fatigue crack is the fatigue-crack-initiation life. The number of cycles required to propagate a fatigue crack to a critical size is called the fatigue-crack-propagation life. The total fatigue life is the sum of the initiation and propagation lives.

Bridge engineers use estimations of total fatigue life in predicting the performance of steel bridge members.

### Types of Fractures

It is common to classify fractures into two failure modes: brittle fracture and ductile fracture.

- Brittle Fracture - Occurs with no warning and without prior plastic deformation (see Figure 8.1.9).
- Ductile Fracture - Generally preceded by local plastic deformation of the net uncracked section. This plastic deformation results in distortion of the member, providing some visual warning of the impending failure (see Figure 8.1.10).



**Figure 8.1.9** Brittle Fracture of Cast Iron Specimen

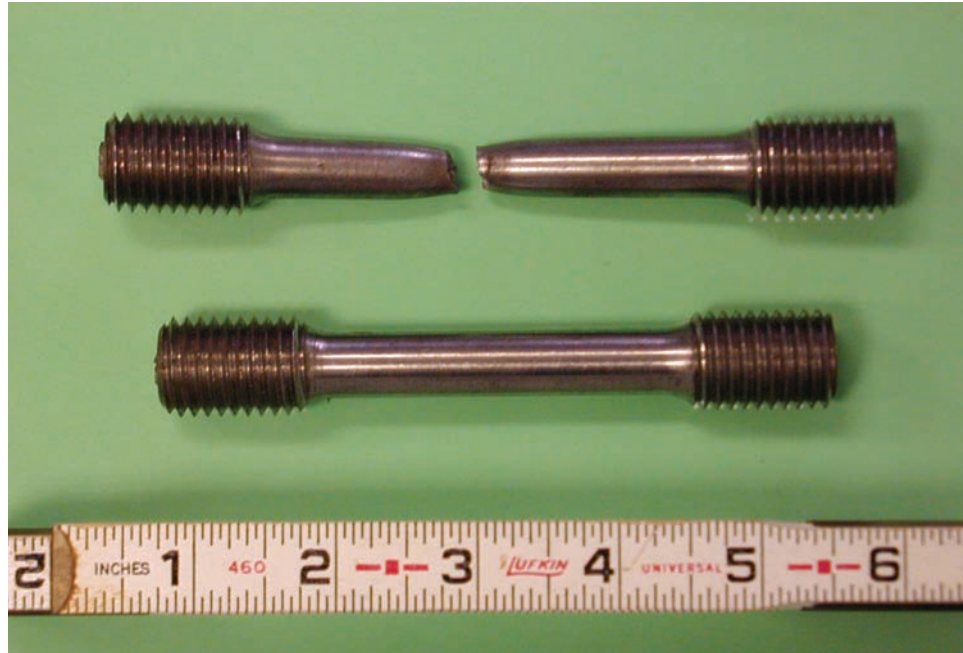

**Figure 8.1.10** Ductile Fracture of Cold Rolled Steel

**Factors that Determine Fracture Behavior**

The transition between a brittle and ductile type of fracture is greatly affected by:

Ambient temperature – Each steel type has a transition temperature below which it becomes brittle.

Loading rate – Truck loading will normally stress the member at an intermediate loading rate which will not create a high energy level. Variations in the speed at which the truck crosses the bridge do not significantly alter the rate of loading. Rapid loading of a steel member, as would occur from a truck collision or an explosion, can create sufficient energy to cause a member to fail in brittle fracture.

Degree of constraint – Thick welded plates or complex joints can produce a high degree of constraint that will limit the steel's ability to deform plastically. Thinner plates are less prone to fracture, given the same conditions, than are thicker plates.

The risk of a brittle fracture in fatigue prone details is greatly increased when the fracture behavior factors include:

- Cold temperature
- Rapid loading
- High constraint

Conversely, some plastic deformation leads to a ductile fracture when the fracture behavior factors are:

- Warm ambient temperature
- Normal truck loading rates
- Low constraint

The transition is a matter of degree. In either case, when it occurs, the fracture of a critical member is sudden and catastrophic.

### Fracture Toughness

The fracture toughness is a measure of the material's resistance to crack extension. Fracture toughness can be defined as the ability of a material to resist crack propagation while under load. Fracture toughness is dependent upon the chemical composition of the material. Steel has greater fracture toughness than iron. Fracture toughness generally depends on temperature, environment, loading rate, the composition of the material, together with geometric effects such as constraint. In general, thick welded members made of steel with low toughness are more likely to fracture on cold days.

An impact test that is used to determine the fracture toughness of a steel specimen or coupon is called the Charpy V-notch test (see Figure 8.1.11). This test measures the amount of energy absorbed by a test specimen prior to failure. The Charpy V-notch test requirements vary depending on the type of steel, type of construction, whether welded or mechanically fastened, and the applicable minimum service temperature.

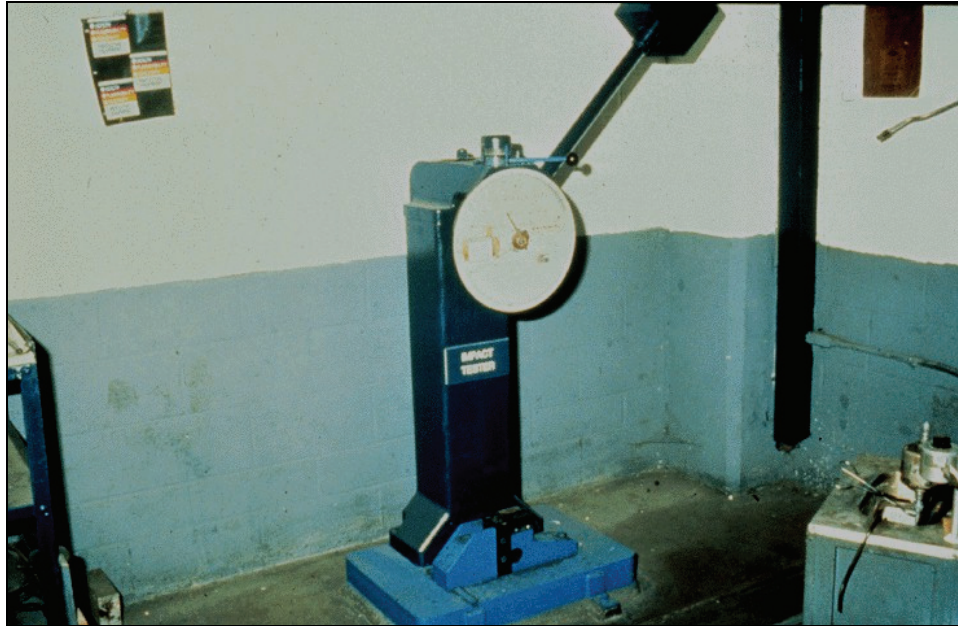

**Figure 8.1.11** Charpy V-notch Testing Machine

### 8.1.3

#### Factors Affecting Fatigue Crack Initiation

Most critical conditions for fatigue crack initiation are those which involve a combination of flaws and stress concentrations. Girders, stringers, floorbeams, diaphragms, bracing, truss members, hangers, and other members must be structurally connected. Bridge structures, particularly those that are welded, cannot be fabricated without details that cause some level of stress concentrations. Good detailing can reduce the number and severity of these stress concentrations in connections.

#### Welds

Welds are the connections of metal parts formed by heating the surfaces to a plastic (or fluid) state and allowing the parts to flow together and join with or without the addition of filler metal. The term base metal refers to the metal parts

that are to be joined. Filler metal, or weld metal, is the additional molten metal generally used in the formation of welds. The complete assembly is referred to as a weldment. Conditions of stress concentration are often found in weldments and can be prone to crack initiation.

The four common types of welds found on bridges are groove welds, fillet welds, plug welds, and tack welds.

**Groove Welds** – Groove welds, which are sometimes referred to as butt welds, are used when the members to be connected are lined up edge to edge or are in the same plane (see Figure 8.1.12). Full penetration groove welds extend through the entire thickness of the piece being joined, while partial penetration groove welds do not. Weld reinforcement is the added filler metal that causes the throat dimension to be greater than the thickness of the base metal. This reinforcement is sometimes ground flush with the base metal to qualify the joint for a better fatigue strength category (see Topic 8.1.5 for descriptions of AASHTO Fatigue Categories).

**Fillet welds** – Fillet welds connect members that either overlap each other or are joined edge to face of plate, as in plate girder assembly of web and flange plates (see Figure 8.1.13). Fillet welds are the most common type of weld because large tolerances in fabrication are allowable when members are lapped over each other instead of fitted together as in groove welds.

**Plug welds** - Plug and slot welds pass through holes in one member to another, with weld metal filling the holes and joining the members together (see Figure 8.1.14). Plug welds have sometimes been used to fill misplaced holes. These repairs are very likely to contain flaws and microcracks that can result in the initiation of fatigue cracking. Plug welds are no longer permitted by AASHTO for bridge construction.

**Tack welds** - Tack welds are small welds commonly used to temporarily hold pieces in position during fabrication or construction (see Figure 8.1.15). They are often made carelessly, without proper procedures or preheating, and can be a fatigue-prone detail.

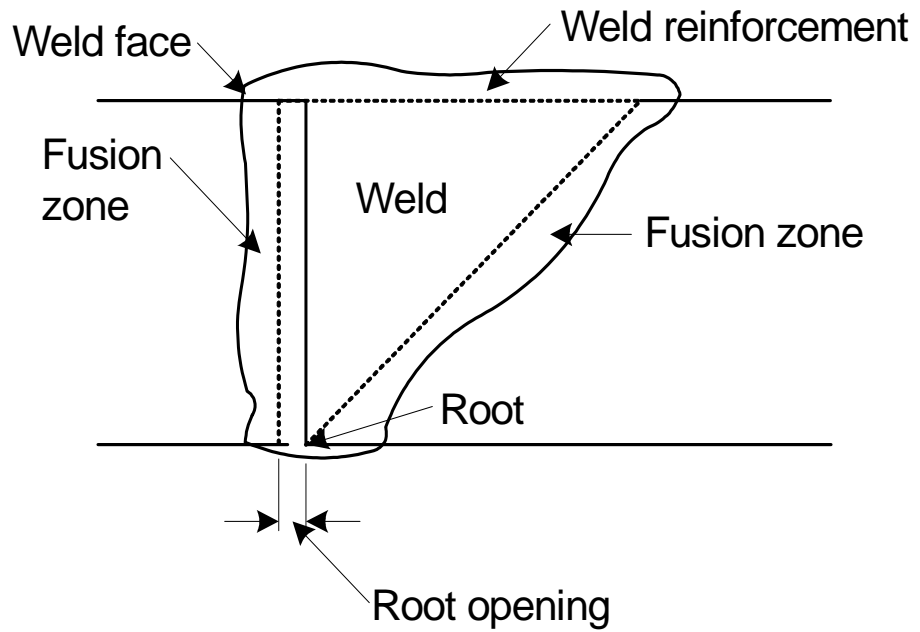

Figure 8.1.12 Groove Weld Nomenclature

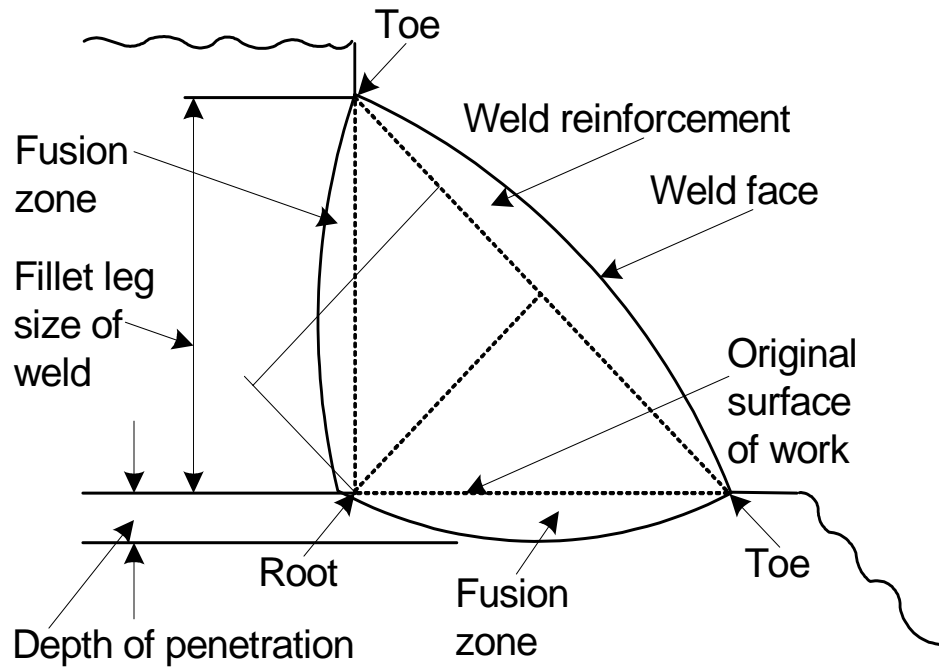
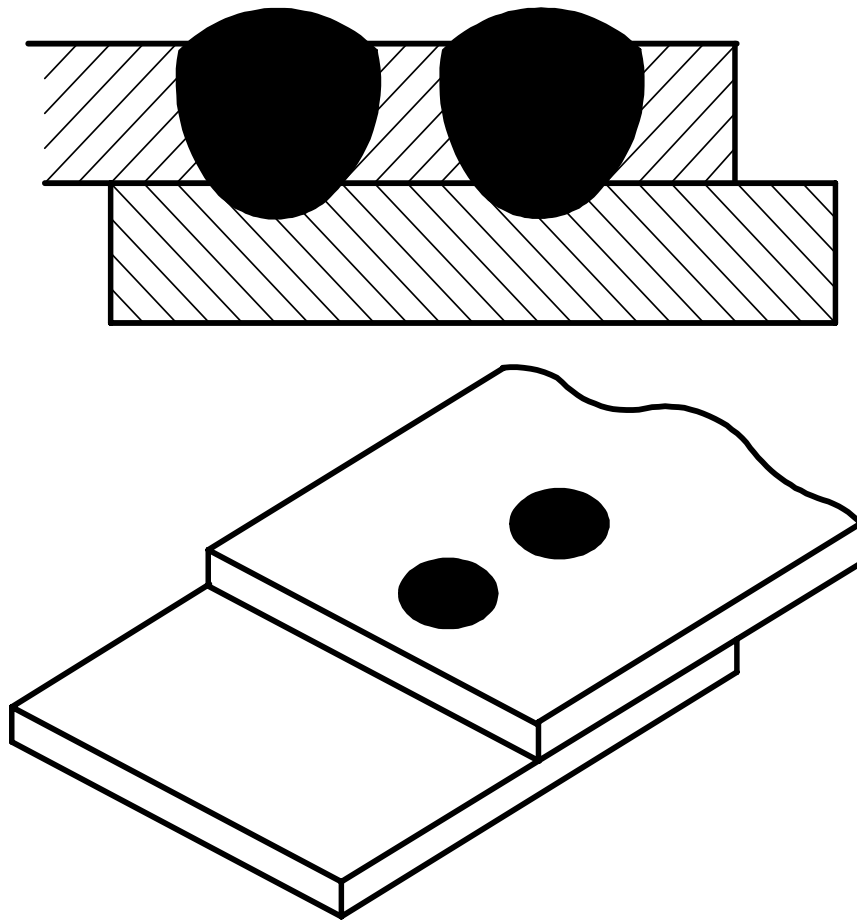

Figure 8.1.13 Fillet Weld Nomenclature



**Figure 8.1.14** Plug Weld Schematic



**Figure 8.1.15** Tack Weld



Both plug and tack welds are smaller than fillet and groove welds but they can be the source of serious problems to bridges.

The joint geometry is also used to describe the weld. Some common weld joints include (see Figure 8.1.16):

- Butt
- Lap
- Tee
- Edge
- Corner

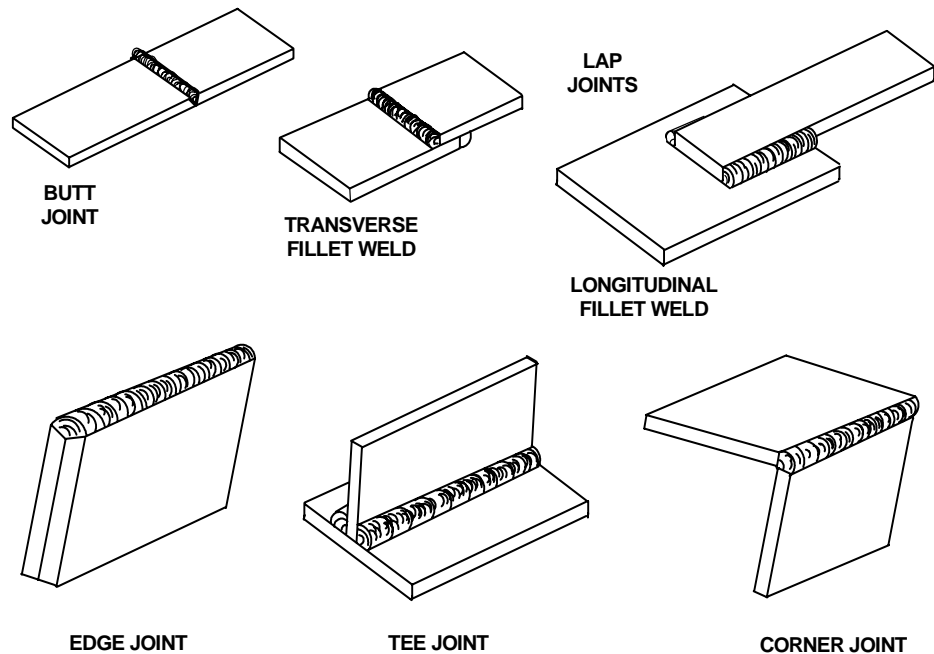

**Figure 8.1.16** Types of Welded Joints

All welding processes result in high built-in residual tension stresses, which are at or near the yield point in the weldment and in the base metal adjacent to it. Load-induced stress concentrations also often occur at welded bridge connections, where these residual tensile stresses are high. This combination of stress concentration and high residual tensile stress is conducive to fatigue crack initiation. Such cracks typically begin either at the weld periphery, such as at the toe of a fillet weld, where there typically can be sharp discontinuities, or else at an internal discontinuity such as a slag inclusion or porosity. In the initial stages of fatigue crack growth, much of the fatigue life is expended by the time a crack has propagated out of the high residual tensile stress zone.

Bridge structures, particularly those that are welded, can contain flaws whose size and distribution depend upon the:

- Quality of weld and base material
- Fabrication methods
- Erection techniques

➤ In-service conditions

Flaws vary in size from very small undetectable nonmetallic inclusions to large inherent weld cracks.

**Material Flaws**

Material flaws may exist in different forms:

- External flaws (e.g., surface laps)
- Internal flaws (e.g., nonmetallic inclusions, laminations and “rolled-in” plate defects (see Figures 8.1.17 & 8.1.18)).



**Figure 8.1.17** Centerline Crack in Steel Slab

The centerline crack in Figure 8.1.17 may have resulted from a shrinkage cavity like that shown in Figure 8.1.18 which was not forged and melded completely in the hot rolling process.

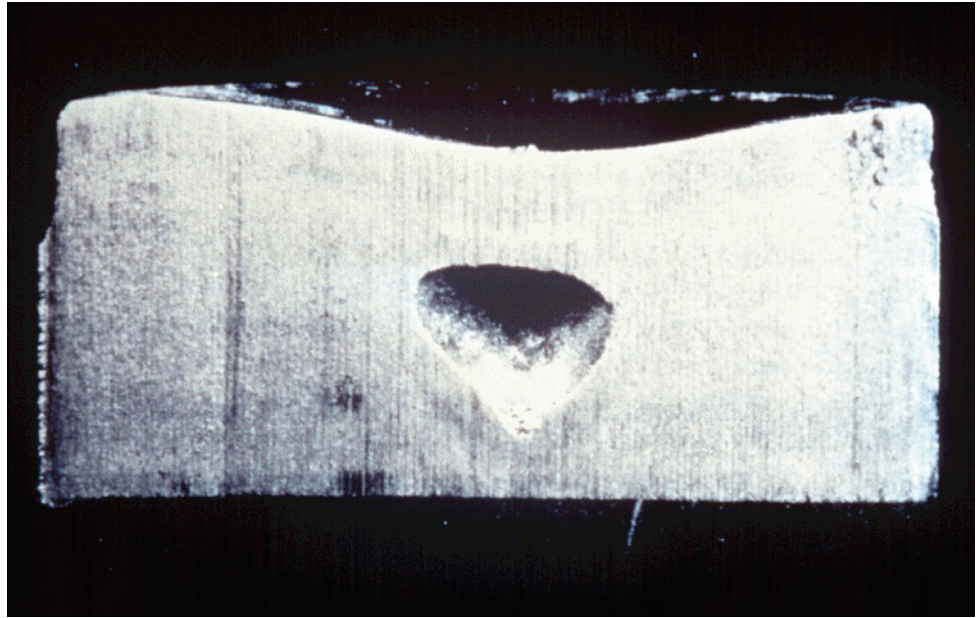

**Figure 8.1.18** Shrinkage Cavity in Steel Billet

### **Fabrication Flaws**

Fabrication can introduce a variety of visible and non-visible flaws. Typical non-visible weld flaws include:

**Incomplete Penetration** – Incomplete penetration occurs when the weld metal fails to penetrate the root of a joint or fails to fuse completely with the root face of the base metal (see Figure 8.1.19). Incomplete penetration is not permitted to any degree. Incomplete penetration welds cause a local stress riser at the root of a weld and can reduce the load carrying capacity of the member. A stress riser is a detail that causes stress concentration.

**Lack of fusion** – Lack of fusion is a condition in which boundaries of unfused metal exist either between base metal and weld metal or between adjacent layers of weld metal (see Figure 8.1.20). Lack of fusion is generally a result of poor welding techniques, can seriously reduce the load carrying capacity of the member, and could be a point of crack initiation at a lower stress.

**Slag inclusions** – Slag inclusion occurs when nonmetallic matter is inadvertently trapped between the weld metal and the base metal (see Figure 8.1.21). Slag from the welding rod shield may be forced into the weld metal by the arc during the welding operation. If large, irregular inclusions or lengthy lines of inclusions are present, crack initiation at a lower stress could begin and the strength of the weld may be considerably reduced. However, small isolated globe shaped inclusions do not seriously affect the strength of a weld, but can be a point of crack initiation.

**Porosity** – Porosity is the presence of cavities in the weld metal caused by entrapped gas and takes the form of small spherical cavities, either scattered throughout the weld or clustered in local regions (see Figure 8.1.22). It is tolerated if the amount does not exceed specified quantities relative to weld size. Sometimes, porosity is visible on the surface of the weld.

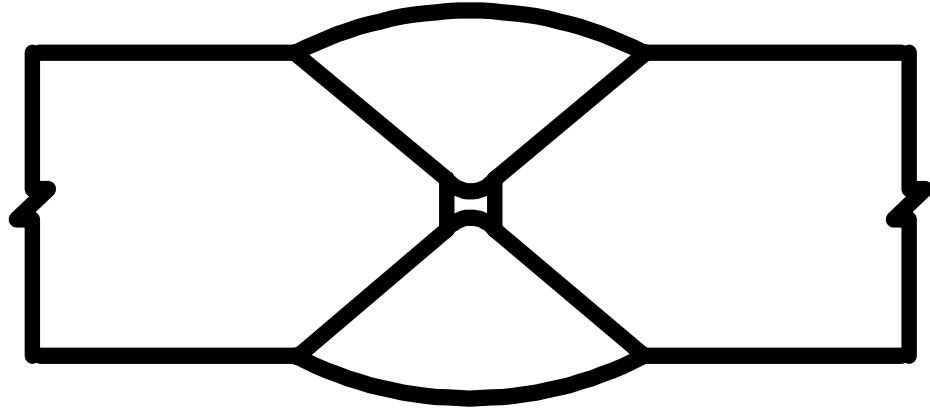

**Figure 8.1.19** Incomplete Penetration of a Double V-Groove Weld

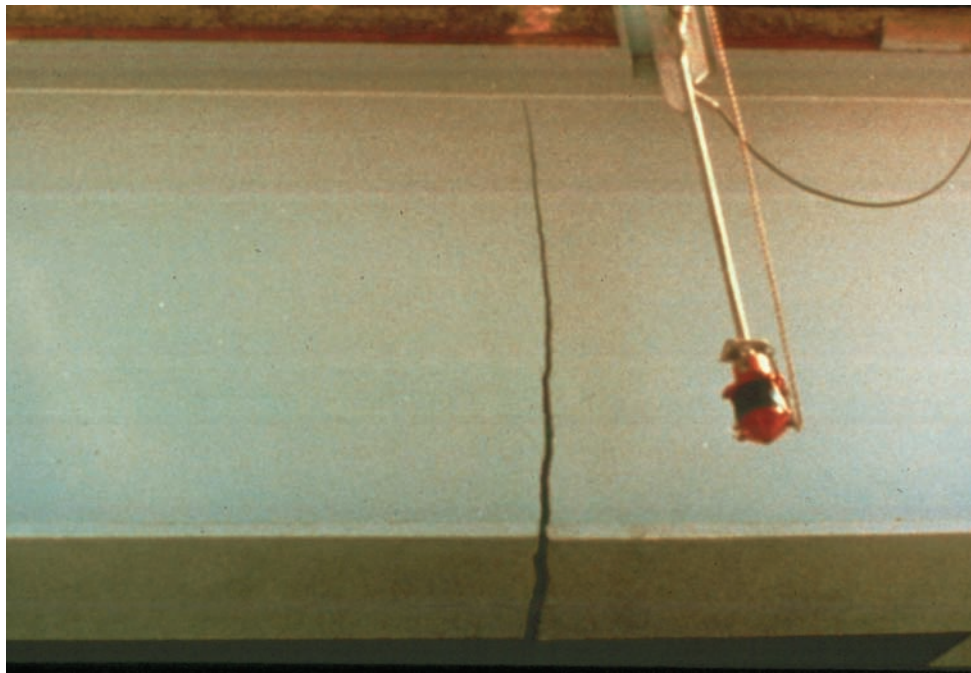

**Figure 8.1.20** Crack Initiation from Lack of Fusion in Heat Affected Zone of Electroslag Groove Weld of a Butt Joint

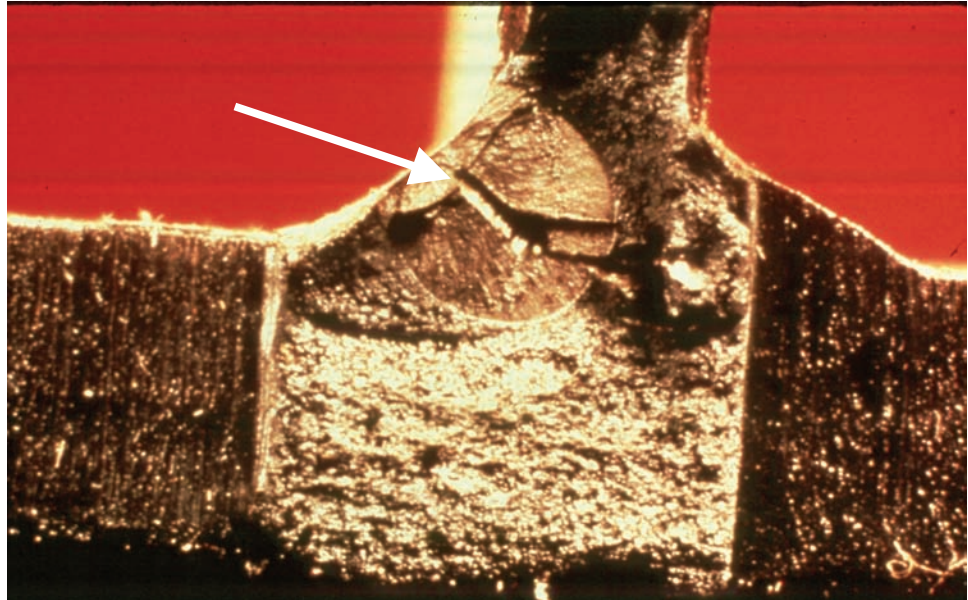

**Figure 8.1.21** Web to Flange Crack due to Fillet Weld Slag Inclusion

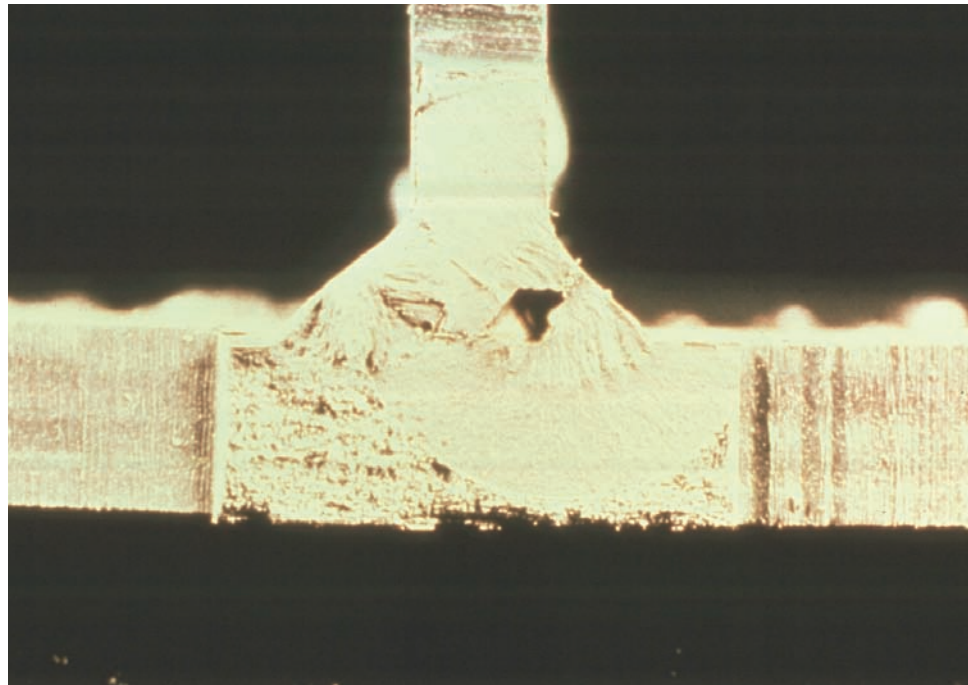

**Figure 8.1.22** Crack Initiation from Porosity in Longitudinal Web-to-Flange Fillet Weld of Plate Girder

Plug welds are sometimes found in bridge members. In most cases, they were made to fill mislocated bolt holes. Such welds are highly restrained and often will contain incomplete penetration, lack of fusion, slag inclusions, and porosity. There have been many instances where a crack and fracture have occurred because of a plug weld (see Figure 8.1.23).



**Figure 8.1.23** Crack Resulting from Plug Welded Holes

Visible weld flaws include:

**Undercut** – The condition in which a local reduction in a section of base metal occurs alongside the weld deposit. This may happen either on the surface of the base metal at the toe of the weld, or in the fusion face of multiple pass welds due to overheating. This groove creates a mechanical notch, which is a stress riser (see Figure 8.1.24). When an undercut is controlled within the limits of specifications and does not constitute a sharp or deep notch, it is not seen as a serious defect.

**Overlap** – Overlap is a weld flaw at the toe of a weld in which the weld metal overflows onto the surface of the base metal without fusing to it due to insufficient heat (see Figure 8.1.25). This condition may exist intermittently or continuously along the weld joint. Discontinuity at the toe of a weld acts as a stress riser and reduces the fatigue strength of the member.

**Bolt and Rivet Holes** – Holes of any kind in the base metal create a stress riser. Punched holes for rivets, without reaming, contain gouges that can initiate a crack. Burrs generated during the drilling process are additional risers and should be removed. However, smooth, round holes are not significant stress risers.

**Beam Coping** – When flange/web copings do not have the proper radius as per AASHTO specifications a stress riser is created (see Figure 8.1.26).

**Flame Cuts** – Flame cutting, although fast, creates large surface discontinuities that are stress risers (see Figure 8.1.27). The surface of flame cut plates in tension should be ground smooth in the direction of the tensile stress.

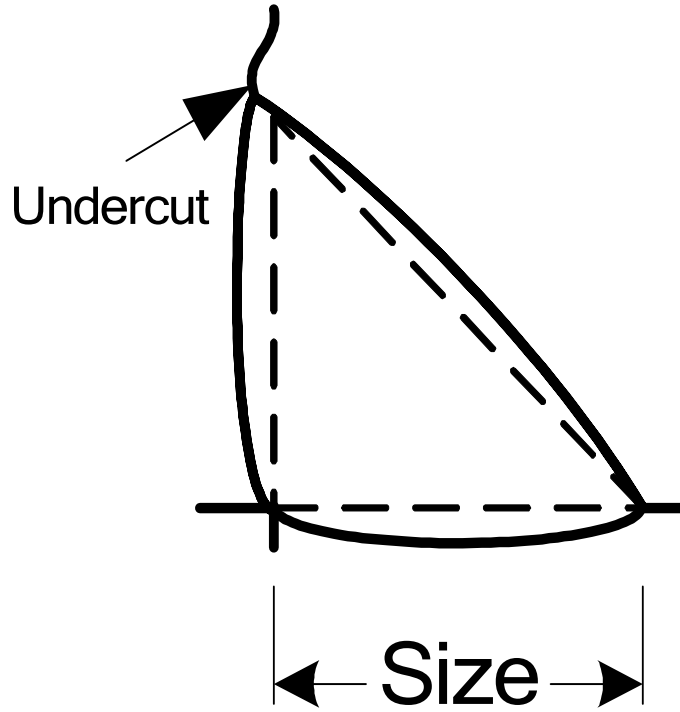

**Figure 8.1.24** Undercut of a Fillet Weld

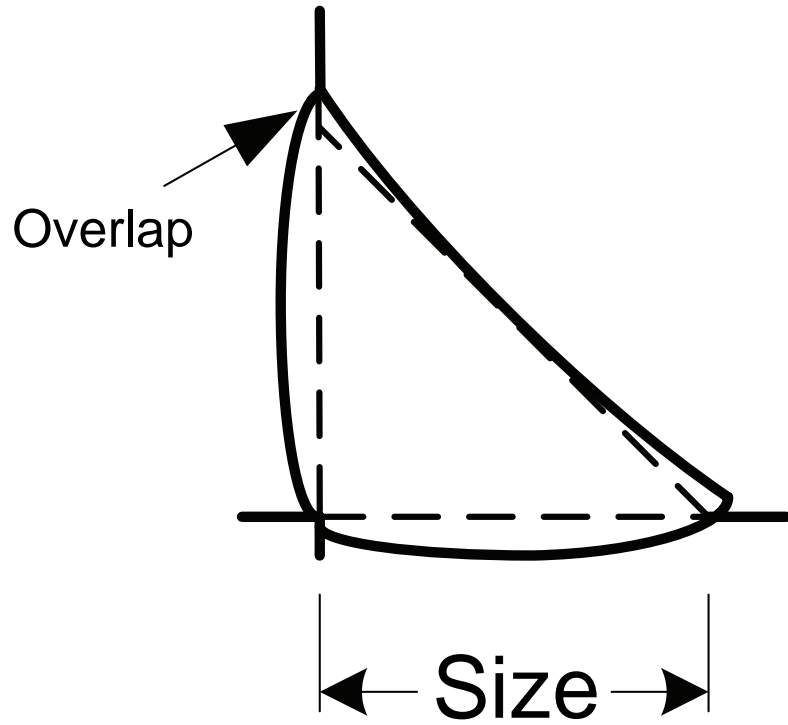

**Figure 8.1.25** Overlap of a Fillet Weld

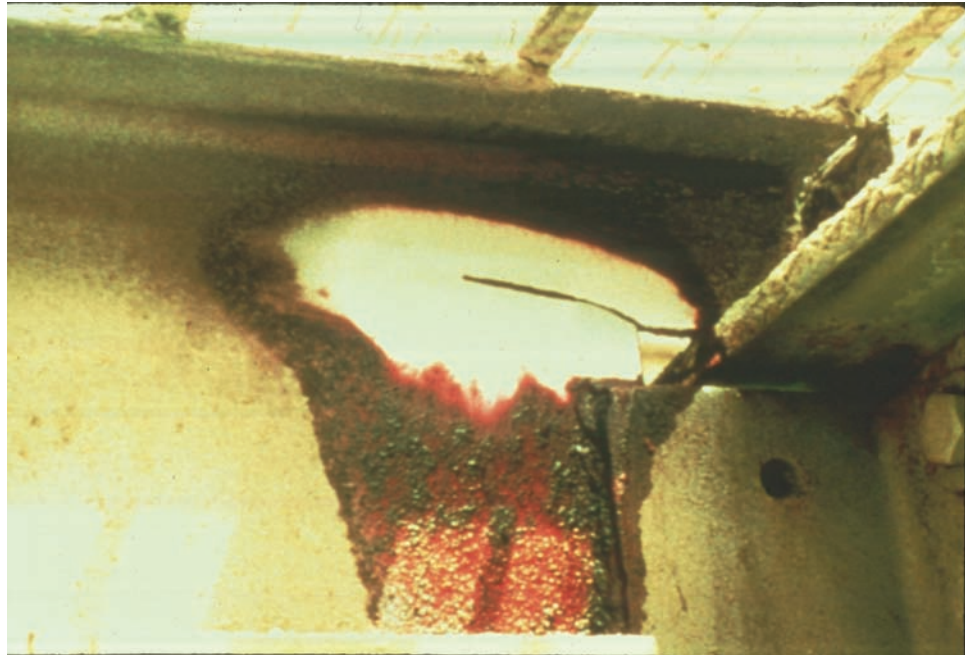

**Figure 8.1.26** Crack Initiation at Coped Web in Stringer to Floorbeam

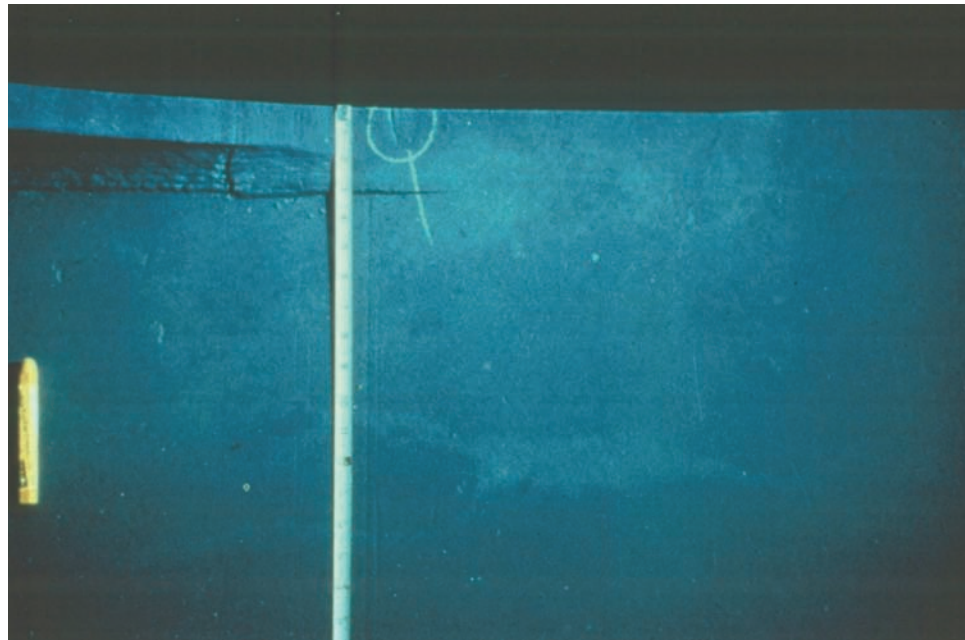

**Figure 8.1.27** Insufficiently Ground Flame Cut of Gusset Plate for Arch to Tie Girder Connection

### Transportation and Erection Flaws

Careless handling during transportation and erection may leave the following flaws along the edges of members:

Nicks, Notches, and Indentations – Beam handling devices such as lifting tongs develop intense pressure at the point of contact and can cause measurable indentations and gouges.

Chain marks – When transporting steel beams, chains are commonly used to secure the beam to the truck or railroad car.



Out-of-Plane Bending Forces – Beams must be securely blocked to resist cyclic sidesway movement during truck or rail transport. There have been extreme cases where cracks have initiated in beams before they have been erected.

Tack Welds – Tack welds were very common in the mid 1950's and through the early 1960's and were used to hold members together during erection. When left in place and exposed to tensile stress, they are a potential crack initiation location.

### **In-Service Flaws**

Once the structure is placed in service, some members may be prone to collision damage by errant vehicles which may nick, tear, and excessively stress the steel (see Figure 8.1.28). Improper heat straightening may damage the steel. Deep corrosion pits can develop in structures that are improperly detailed for corrosion control, poorly maintained, or left unpainted. Also, any indiscriminate welding of conduit supports, lighting attachments, and ladder brackets to steel members can cause stress risers in the base metal.



**Figure 8.1.28** Severe Collision Damage on a Fascia Girder

In summary, bridges can contain significant flaws that can be the point of initiation of fatigue cracking and possibly result in fracture. Their presence must be presumed, and inspection must be diligent to identify them in order to permit timely corrective measures whenever appropriate.

### **8.1.4**

#### **Factors Affecting Fatigue Crack Propagation**

Failures due to cracking develop as a result of cyclic loading and usually provide little evidence of plastic deformation. Hence, they are often difficult to see before serious distress develops in the member. Fatigue cracks generally require large magnitudes of cyclic stresses, corresponding to a high frequency of occurrence or to a long exposure time. Structural details have various amounts of resistance to fatigue cracks caused by these large magnitudes of cyclic stresses. The three major parameters affecting fatigue crack propagation life are:

- Stress range
- Number of cycles
- Type of details

### Stress Range

The stress range is defined as the algebraic difference between the maximum stress and the minimum stress calculated at the detail under consideration. In other words, it is the value of the cyclic stress caused by a truck crossing the bridge (see Figure 8.1.29). The weight of the bridge produces a constant stress instead of a cyclic stress. Therefore, it does not affect the crack propagation life. Only stress ranges in tension or stress reversal can drive fatigue cracks to failure. Stress ranges in compression may cause cracks to grow to some extent at weldments where there are high residual tensile stresses. However, these "compression" cracks eventually arrest, and they do not induce fracture of the member.

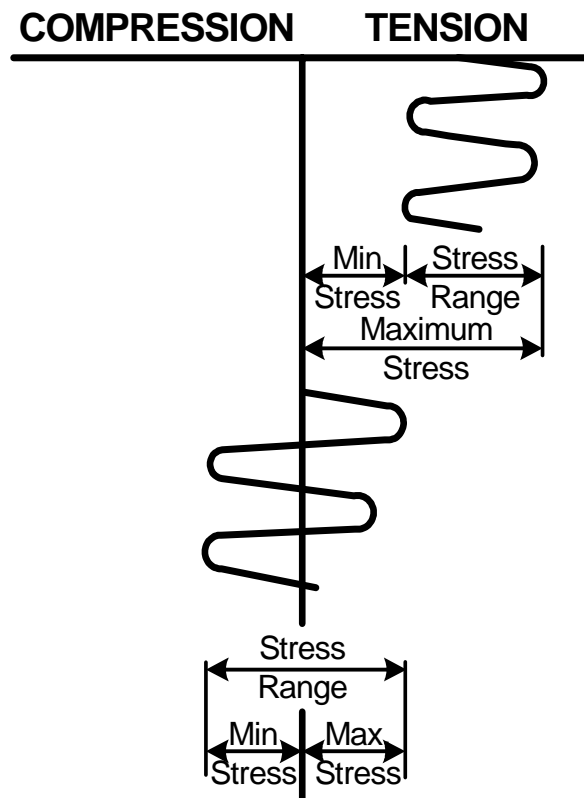

**Figure 8.1.29** Applied Tensile and Compressive Stress Cycles

### Number of Cycles

The number of stress cycles is proportional to the number of trucks that cross the bridge during its service life. The number of cycles per truck passage depends upon span arrangement, member orientation, structure type, and location relative to interior supports. In some bridges, stress cycles are induced by wind loading.

### Types of Details

There are many details used in the connections of bridges. AASHTO has chosen some typical details, or Illustrative Examples (see Figure 8.1.30). These Illustrative Examples are used to help determine AASHTO Fatigue Categories (see Topic 8.1.5).

SECTION 8: Inspection and Evaluation of Common Steel Superstructures  
 TOPIC 8.1: Fatigue and Fracture in Steel Bridges

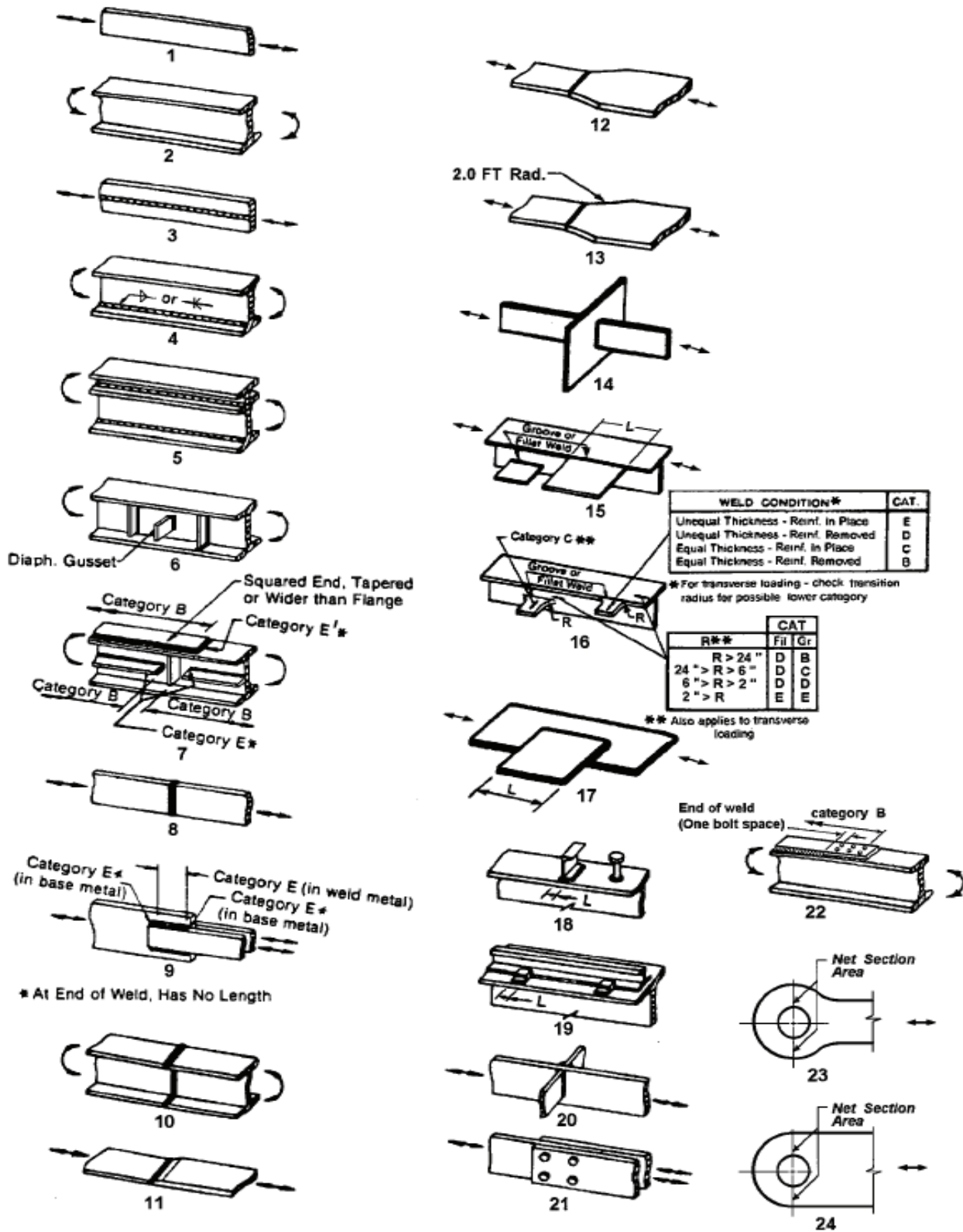

Figure 8.1.30 AASHTO LRFD Bridge Design Specifications, 3<sup>rd</sup> Edition, with 2005 Interim Revisions, Figure 6.6.1.2.3-1 - Illustrative Examples of Bridge Details

Various details will have different fatigue strengths associated with them. It is common practice among bridge engineers to group steel bridge structural details into a number of categories. By doing this, the bridge engineer can design against risk levels of fatigue failure of the various details (i.e., details of higher fatigue strength categories are allowed higher stress ranges than the lower category details).

**Flange Crack Failure Process**

A common location for initiation of a flange crack is at the end of a partial length cover plate welded longitudinally along its sides and transversely across the ends as it is attached to the tension flange of a rolled beam.

One or more cracks can initiate from microscopic flaws or defects at the weld toe of the transverse end weld (see Figure 8.1.31). Such cracking may then advance in three stages:



**Figure 8.1.31** Part-Through Crack at a Cover Plated Flange

**Stage 1**

In the first stage, a part-through surface crack is only barely visible as a hairline on the bottom of the flange at the toe of weld. As stress is applied, the small cracks that have initiated join each other and begin to form a larger part-through surface crack (see Figure 8.1.32).



**Figure 8.1.32** Part-Through Crack Growth at Cover Plate Welded to Flange

The crack front develops a thumbnail or half penny shape as it propagates in the thickness direction of the flange until reaching the inside surface. Once it breaks through the thickness of the flange, the shape rapidly changes into that of a three-ended crack.

Crack propagation begins at a very slow rate and gradually accelerates as the crack grows in size. Approximately 95% of the fatigue life is spent growing the Stage 1 part-through crack.

#### Stage 2

During the second stage, the crack then propagates with two fronts moving across the flange width and one front moving into the web until it reaches a critical size, at which time the member may fracture (see Figure 8.1.33).

The crack is readily visible as a through-the-thickness crack on both the top and bottom surfaces of the flange (see Figure 8.1.34).

Approximately 5% of the fatigue life is left for growing the Stage 2 through crack (see Figure 8.1.35).

#### Stage 3

When a crack propagates to a critical size, the member will fracture. Fracture is the separation of the member into two parts. When the member is fracture critical, the span, or a portion of it, would likely collapse.

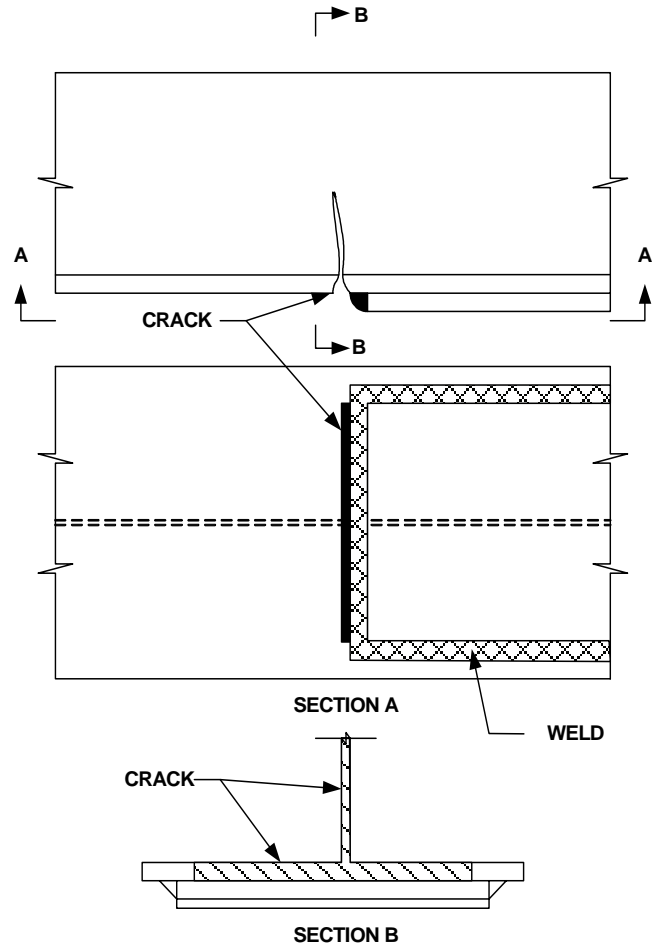

**Figure 8.1.33** Through Crack Growth at Cover Plate Welded to Flange

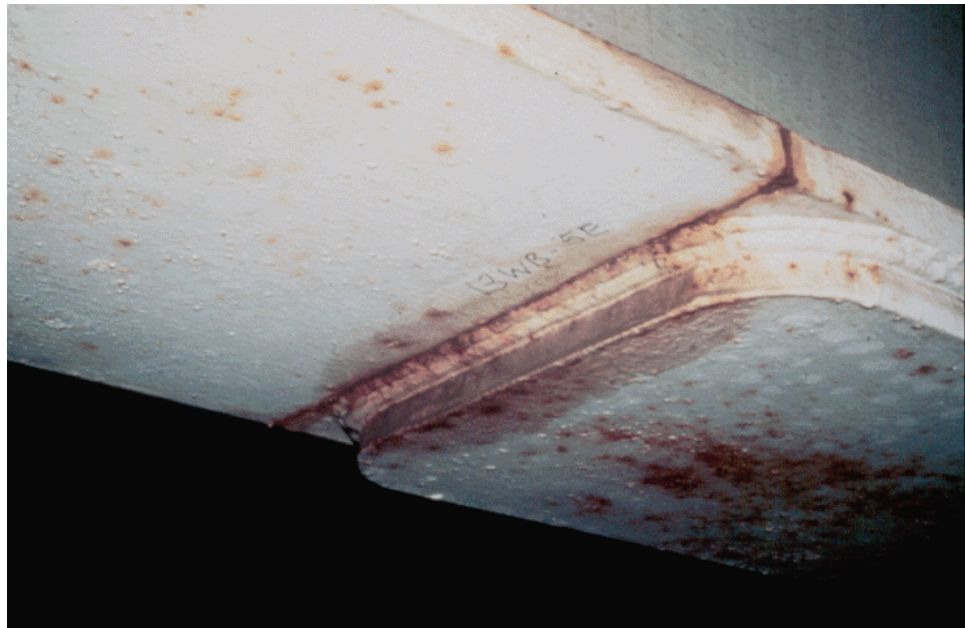

**Figure 8.1.34** Through Crack at a Cover Plated Flange

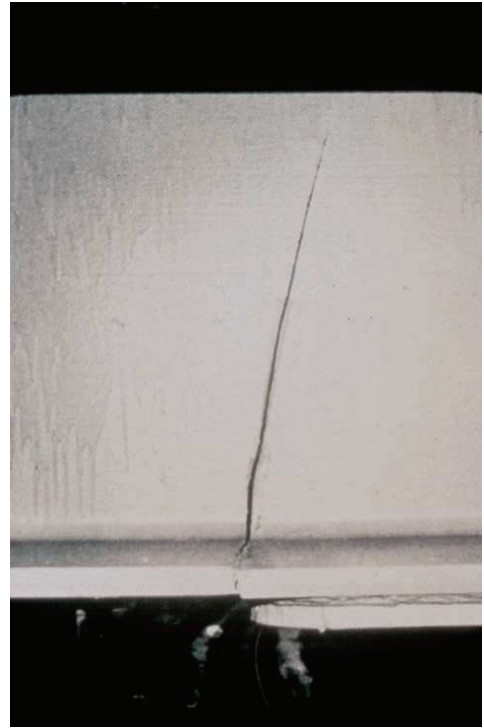
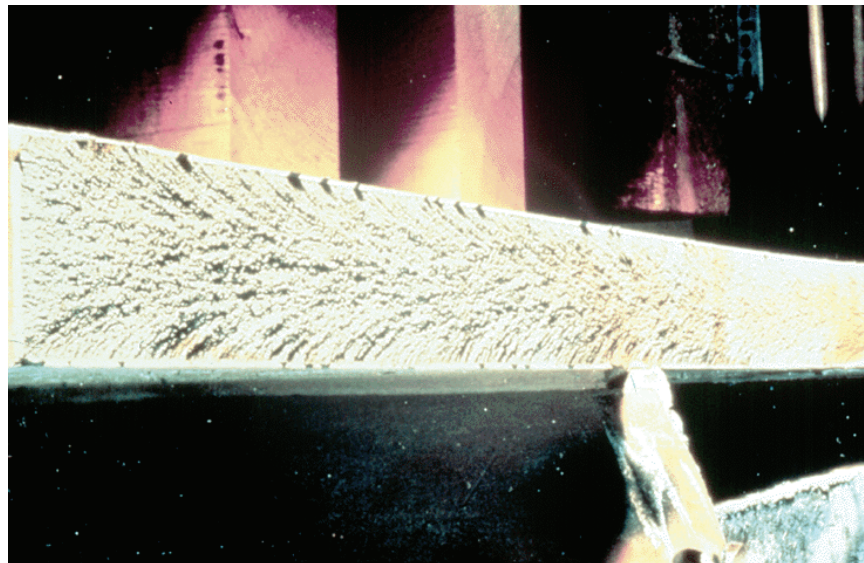

**Figure 8.1.35** Through Crack has Propagated into the Web

#### Inspection

It is important the inspector realizes that cracks are only readily detectable visually as a through crack after most of the fatigue life of the detail is gone. Therefore, a structural engineer must be notified immediately whenever cracks are found in a flange.

When the fatigue life is finally used up, that is the fatigue crack has grown to a critical size and stress intensity, then fracture will occur. The brittle fracture surface will appear crystalline or uneven, and will often reveal a herringbone pattern oriented toward the point of fracture initiation (see Figure 8.1.36).



**Figure 8.1.36** Brittle Fracture – Herringbone Pattern

**Web Crack Failure Process**

A common location for initiation of a web crack is at the weld toe of a transverse stiffener that is welded to the web of a beam. This type of crack grows in three stages (see Figure 8.1.37):

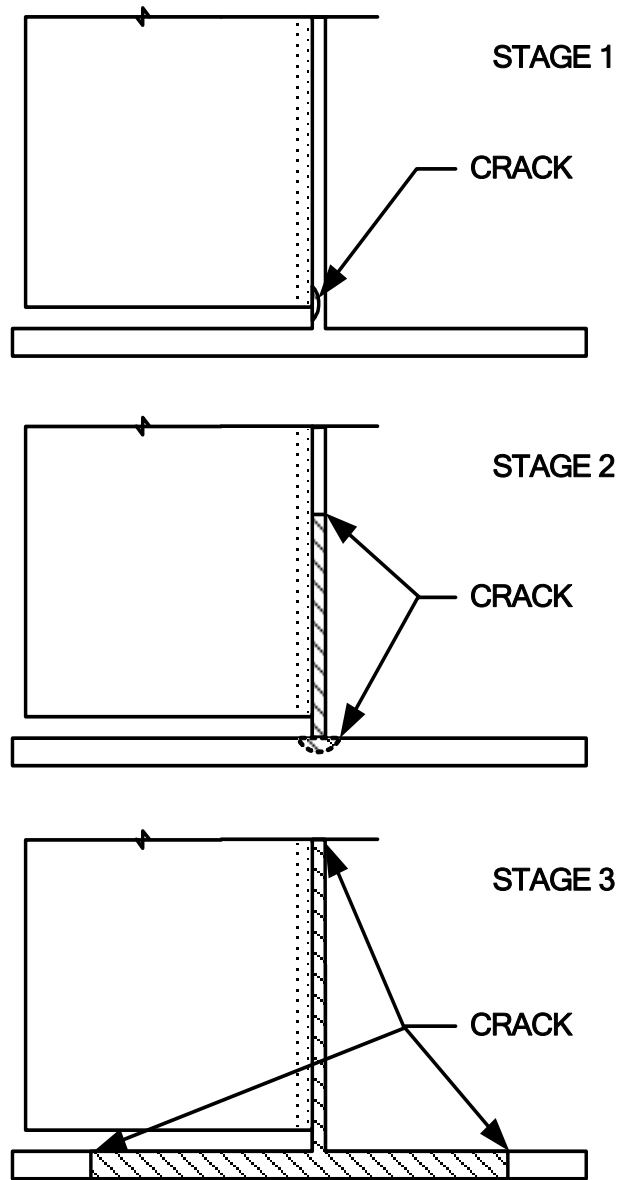

**Figure 8.1.37** Crack Growth at Transverse Stiffener Welded to Web

**Stage 1**

A fatigue crack initiates at the weld toe near the end of the stiffener and propagates during the first stage as a part-through crack in the thickness direction of the web until it reaches the opposite face of the web.

A part-through stiffener crack is often just barely visible as a hairline along the toe of the weld (see Figure 8.1.38).



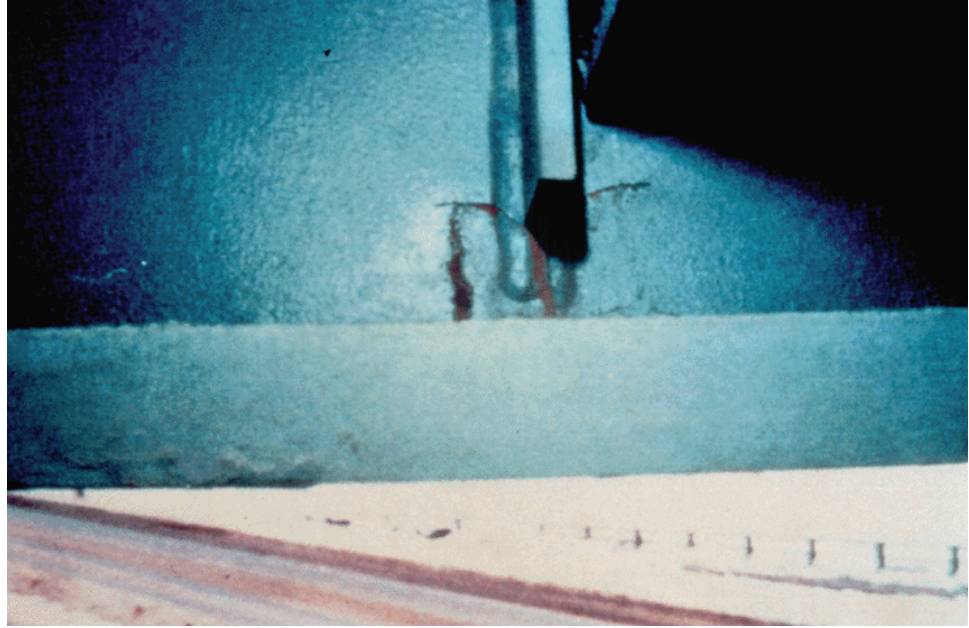

**Figure 8.1.38** Part-Through Web Crack

This type of stiffener crack expends about 95% of its fatigue life propagating in Stage 1.

Stage 2

After it breaks through the web, the shape changes into a two-ended (or more) through crack which propagates up and down the web (see Figure 8.1.39). The through crack can be readily seen on both sides of the web. The stiffener crack expends about 5% of the fatigue life propagating in Stage 2.



**Figure 8.1.39** Through Crack in the Web

Stage 3

Eventually, the lower crack front will reach the bottom flange, and the three-ended crack will then propagate with two fronts moving across the flange and one front moving farther up the web, until the member fractures (see Figure 8.1.40).



**Figure 8.1.40** Through-Crack Ready to Propagate into the Flange

The through crack can usually readily be seen on both sides of the web and on both sides of the flange.

Any web cracks discovered should be brought to the immediate attention of a bridge engineer.

## 8.1.5

### **AASHTO Detail Categories for Load-Induced Fatigue**

For purposes of designing bridges for fatigue caused by in-plane bending stress, the details are grouped into categories labeled A to E' (see Figure 8.1.41). The classification of details by category does not apply to details that crack due to out-of-plane distortion. Each letter represents a rating given to a detail that indicates its level of fatigue strength. The details assigned to the same category have about equally severe stress concentrations and comparable fatigue lives. The alphabetical classification by the severity of the stress concentration is a useful method of identifying fatigue strength.

When used in inspection, these fatigue categories serve as a reminder of which details are prone to fatigue cracking. The categories are defined as follows.

#### **Category A**

Includes “base metal” or plain material with rolled or cleaned surfaces, away from welded, riveted or bolted connections.

This condition has the best fatigue resistance.

It is not common practice to examine these base metal regions for fatigue cracks

unless the regions are susceptible to distortion, because cracks usually develop at nearby connection details with lower fatigue strength categories.

**Category B**

Includes the following welded structural details and high strength bolted joints:

- Longitudinal continuous welds in built-up plates and shapes.
- Transverse full penetration groove welds with weld reinforcement ground smooth and weld soundness established by non-destructive testing (NDT).
- Groove welded attachments with a transition radius not less than 610 mm (24 inches).
- High strength bolted connections.

**Category B'**

Sub-category including details similar to those of Category B, but found to be more sensitive to fatigue:

- Longitudinal continuous welds in built-up plates and shapes not detailed in Category B.
- Transverse full penetration groove welds with reinforcement ground smooth to provide straight transition in width or thickness, slopes of transition not steeper than 1 to 2.5, and base metal A514 or A517.

**Category C and C'**

Includes transverse stiffeners, very short attachments, and transverse groove welds with reinforcement not removed.

- Base metal at welds connecting transverse stiffeners or vertical gusset plates to connection and gusset plates of girder webs or flanges.
- Transverse full penetration groove welds, weld reinforcement not removed, but with weld soundness established by NDT.
- Groove or fillet welded horizontal gusset or attachment, the length of which (in the direction of the main member) is less than 50 mm (2 inches).
- Groove welded attachments 150 to 610 mm (6 to 24 inches) in length with transition radius.
- Intersecting plates connected by fillet welds with the discontinuous plate not more than 13 mm (½ inch) thick.
- Shear connectors.

**Category D**

Includes welded short attachments, welded connections with sharp transition curves, and riveted joints.

- Welded attachments with a short groove or fillet weld in the direction of the main member between 50 and 100 mm (2 and 4 inches) long but less than 12 times the plate thickness.

- Groove welded attachments with transition radius between 50 and 150 mm (2 and 6 inches).
- Groove welded attachments with unequal plate thickness, weld perpendicular to attachment, weld reinforcement removed, and a transition radius of at least 50 mm (2 inches).
- Longitudinally loaded fillet weld with length in the direction of stress of 50 to 100 mm (2 to 4 inches).
- Riveted connections, net section.

**Category E and E'**

Includes details that have the lowest fatigue strength in comparison to those in other categories. Generally, for welded details in this group with the same configurations, Category E' applies if the flange plate thickness exceeds 20 mm (0.8 inch) or if the attachment plate thickness is 25 mm (1 inch) or more.

- Ends of partial length cover plates on girder or beam flanges.
- Welded attachment, with groove or fillet weld in the direction of the main members, more than 100 mm (4 inches) or 12 times the plate thickness.
- Welded attachment with curved transition radius.
- Welded attachment with loads transverse to welds.
- Intermittent fillet welds
- Shear stress on the throat of a fillet weld (Formerly classified Category F)
- Deck plate at the connection to floorbeam web.

Of all the details, those in Categories E and E' are the most susceptible to fatigue crack growth. These details should be closely examined at every inspection.

SECTION 8: Inspection and Evaluation of Common Steel Superstructures  
TOPIC 8.1: Fatigue and Fracture in Steel Bridges

GENERAL CONDITION	SITUATION	DETAIL CATEGORY	ILLUSTRATIVE EXAMPLE, SEE FIGURE 6.6.1.2.3-1	
Plain Members	Base metal:		1, 2	
	<ul style="list-style-type: none"> <li>• With rolled or cleaned surfaces; flame-cut edges with ANSI/AASHTO/AWS D1.5 (Section 3.2.2) smoothness of 1,000 <math>\mu</math> - in. or less</li> </ul>	A		
	<ul style="list-style-type: none"> <li>• Of unpainted weathering steel, all grades, designed and detailed in accordance with FHWA (1989)</li> <li>• At net section of eyebar heads and pin plates</li> </ul>	B  E		
Builtup Members	Base metal and weld metal in components, without attachments, connected by:		3, 4, 5, 7	
	<ul style="list-style-type: none"> <li>• Continuous full-penetration groove welds with backing bars removed, or</li> </ul>	B		
	<ul style="list-style-type: none"> <li>• Continuous fillet welds parallel to the direction of applied stress</li> </ul>	B		
	<ul style="list-style-type: none"> <li>• Continuous full-penetration groove welds with backing bars in place, or</li> </ul>	B'		
	<ul style="list-style-type: none"> <li>• Continuous partial-penetration groove welds parallel to the direction of applied stress</li> </ul>	B'		
	Base metal at ends of partial-length cover plates:			
	<ul style="list-style-type: none"> <li>• With bolted slip-critical end connections</li> </ul>	B	22	
<ul style="list-style-type: none"> <li>• Narrower than the flange, with or without end welds, or wider than the flange with end welds <ul style="list-style-type: none"> <li>• Flange thickness <math>\leq</math> 0.8- in.</li> <li>• Flange thickness <math>&gt;</math> 0.8- in.</li> </ul> </li> <li>• Wider than the flange without end welds</li> </ul>	E E' E'	7		

**Figure 8.1.41** *AASHTO LRFD Bridge Design Specifications, 3<sup>rd</sup> Edition, with 2005 Interim Revisions, Table 6.6.1.2.3-1 - Fatigue Categories of Bridge Details*

SECTION 8: Inspection and Evaluation of Common Steel Superstructures  
TOPIC 8.1: Fatigue and Fracture in Steel Bridges

GENERAL CONDITION	SITUATION	DETAIL CATEGORY	ILLUSTRATIVE EXAMPLE, SEE FIGURE 6.6.1.2.3-1
Groove-Welded Splice Connections with Weld Soundness Established by NDT and All Required Grinding in the Direction of the Applied Stresses	Base metal and weld metal at full-penetration groove-welded splices:		
	<ul style="list-style-type: none"> <li>• Of plates of similar cross-sections with welds ground flush</li> </ul>	B	8, 10
	<ul style="list-style-type: none"> <li>• With 2.0 ft. radius transitions in width with welds ground flush</li> </ul>	B	13
	<ul style="list-style-type: none"> <li>• With transitions in width or thickness with welds ground to provide slopes no steeper than 1.0 to 2.5                             <ul style="list-style-type: none"> <li>• Grades 100/100W base metal</li> <li>• Other base metal grades</li> </ul> </li> <li>• With or without transitions having slopes no greater than 1.0 to 2.5 when weld reinforcement is not removed</li> </ul>	B' B C	11, 12  8, 10, 11, 12
Longitudinally Loaded Groove-Welded Attachments	Base metal at details attached by full- or partial-penetration groove welds:		
	<ul style="list-style-type: none"> <li>• When the detail length in the direction of applied stress is:</li> </ul>		
	<ul style="list-style-type: none"> <li> <ul style="list-style-type: none"> <li>• Less than 2.0 in.</li> </ul> </li> </ul>	C	6, 15
	<ul style="list-style-type: none"> <li> <ul style="list-style-type: none"> <li>• Between 2.0 in. and 12 times the detail thickness, but less than 4.0 in.</li> </ul> </li> </ul>	D	15
	<ul style="list-style-type: none"> <li> <ul style="list-style-type: none"> <li>• Greater than either 12 times the detail thickness or 4.0 in.</li> </ul> </li> </ul>		
	<ul style="list-style-type: none"> <li> <ul style="list-style-type: none"> <li> <ul style="list-style-type: none"> <li>• Detail thickness &lt; 1.0- in.</li> </ul> </li> </ul> </li> </ul>	E	15
	<ul style="list-style-type: none"> <li> <ul style="list-style-type: none"> <li> <ul style="list-style-type: none"> <li>• Detail thickness ≥ 1.0- in.</li> </ul> </li> </ul> </li> </ul>	E'	15
	<ul style="list-style-type: none"> <li>• With a transition radius with the end welds ground smooth, regardless of detail length:</li> </ul>		
<ul style="list-style-type: none"> <li> <ul style="list-style-type: none"> <li>• Transition radius ≥ 24.0 in.</li> </ul> </li> </ul>	B		
<ul style="list-style-type: none"> <li> <ul style="list-style-type: none"> <li>• 24.0 in. &gt; transition radius ≥ 6.0 in.</li> </ul> </li> </ul>	C		
<ul style="list-style-type: none"> <li> <ul style="list-style-type: none"> <li>• 6.0 in. &gt; transition radius ≥ 2.0 in.</li> </ul> </li> </ul>	D		
<ul style="list-style-type: none"> <li> <ul style="list-style-type: none"> <li>• Transition radius &lt; 2.0 in.</li> </ul> </li> </ul>	E		
<ul style="list-style-type: none"> <li>• With a transition radius with end welds not ground smooth</li> </ul>	E	16	

**Figure 8.1.41** AASHTO LRFD Bridge Design Specifications, 3<sup>rd</sup> Edition, with 2005 Interim Revisions, Table 6.6.1.2.3-1 - Fatigue Categories of Bridge Details, continued

SECTION 8: Inspection and Evaluation of Common Steel Superstructures  
TOPIC 8.1: Fatigue and Fracture in Steel Bridges

GENERAL CONDITION	SITUATION	DETAIL CATEGORY	ILLUSTRATIVE EXAMPLE, SEE FIGURE 6.6.1.2.3-1
Transversely Loaded Groove-Welded Attachments with Weld Soundness Established by NDT and All Required grinding Transverse to the Direction of Stress	<p>Base metal at detail attached by full-penetration groove welds with a transition radius:</p> <ul style="list-style-type: none"> <li>• With equal plate thickness and weld reinforcement removed: <ul style="list-style-type: none"> <li>• Transition radius <math>\geq</math> 24.0 in.</li> <li>• 24.0 in. &gt; transition radius <math>\geq</math> 6.0 in.</li> <li>• 6.0 in. &gt; transition radius <math>\geq</math> 2.0 in.</li> <li>• Transition radius &lt; 2.0 in.</li> </ul> </li> <li>• With equal plate thickness and weld reinforcement not removed: <ul style="list-style-type: none"> <li>• Transition radius <math>\geq</math> 6.0 in.</li> <li>• 6.0 in. &gt; transition radius <math>\geq</math> 2.0 in.</li> <li>• Transition radius &lt; 2.0 in.</li> </ul> </li> <li>• With unequal plate thickness and weld reinforcement removed: <ul style="list-style-type: none"> <li>• Transition radius <math>\geq</math> 2.0 in.</li> <li>• Transition radius &lt; 2.0 in.</li> </ul> </li> <li>• For any transition radius with unequal plate thickness and weld reinforcement not removed</li> </ul>	B	16
		C	
		D	
		E	
		C	
		D	
		E	
		D	
		E	
		E	
Fillet-Welded Connections with Welds Normal to the Direction of Stress	<p>Base metal:</p> <ul style="list-style-type: none"> <li>• At details other than transverse stiffener-to-flange or transverse stiffener-to-web connections</li> <li>• At the toe of transverse stiffener-to-flange and transverse stiffener-to-web welds</li> </ul>	Lesser of C or Equation 6.6.1.2.5-3	14
		C'	6
Fillet-Welded Connections with Welds Normal and/or parallel to the Direction of Stress	Shear stress on the weld throat	E	9

**Figure 8.1.41** AASHTO LRFD Bridge Design Specifications, 3<sup>rd</sup> Edition, with 2005 Interim Revisions, 6.6.1.2.3-1 - Fatigue Categories of Bridge Details, continued

SECTION 8: Inspection and Evaluation of Common Steel Superstructures  
TOPIC 8.1: Fatigue and Fracture in Steel Bridges

GENERAL CONDITION	SITUATION	DETAIL CATEGORY	ILLUSTRATIVE EXAMPLE, SEE FIGURE 6.6.1.2.3-1
Longitudinally Loaded Fillet-Welded Attachments	<p>Base metal at details attached by fillet welds:</p> <ul style="list-style-type: none"> <li>• When the detail length in the direction of applied stress is: <ul style="list-style-type: none"> <li>• Less than 2.0 in. or stud-type shear connectors</li> <li>• Between 2.0 in. and 12 times the detail thickness, but less than 4.0 in.</li> <li>• Greater than either 12 times the detail thickness or 4.0 in. <ul style="list-style-type: none"> <li>• Detail thickness &lt; 1.0- in.</li> <li>• Detail thickness ≥ 1.0- in.</li> </ul> </li> </ul> </li> <li>• With a transition radius with the end welds ground smooth, regardless of detail length <ul style="list-style-type: none"> <li>• Transition radius ≥ 2.0 in.</li> <li>• Transition radius &lt; 2.0 in.</li> </ul> </li> <li>• With a transition radius with end welds not ground smooth</li> </ul>	C	15, 17, 18, 20
		D	15, 17
		E	7, 9, 15, 17
		E'	
		D	16
		E	16
Transversely Loaded Fillet-Welded Attachments with Welds Parallel to the Direction of Primary Stress	<p>Base metal at details attached by fillet welds:</p> <ul style="list-style-type: none"> <li>• With a transition radius with end welds ground smooth: <ul style="list-style-type: none"> <li>• Transition radius ≥ 2.0 in.</li> <li>• Transition radius &lt; 2.0 in.</li> </ul> </li> <li>• With a transition radius with end welds not ground smooth</li> </ul>	D	16
E	E		
Mechanically Fastened Connections	<p>Base metal:</p> <ul style="list-style-type: none"> <li>• At gross section of high-strength bolted slip-critical connections, except axially loaded joints in which out-of-plane bending is induced in connected materials</li> <li>• At net section of high-strength bolted nonslip-critical connections</li> <li>• At net sections of riveted connections</li> </ul>	B	21
		B	
		D	

**Figure 8.1.41** *AASHTO LRFD Bridge Design Specifications, 3<sup>rd</sup> Edition, with 2005 Interim Revisions, Table 6.6.1.2.3-1 - Fatigue Categories of Bridge Details, continued*



SECTION 8: Inspection and Evaluation of Common Steel Superstructures  
 TOPIC 8.1: Fatigue and Fracture in Steel Bridges

GENERAL CONDITION	SITUATION	DETAIL CATEGORY	ILLUSTRATIVE EXAMPLE, SEE FIGURE 6.6.1.2.3-1
Eyebars or Pin Plates	Base metal at the net section of eyebar head, or pin plate	E	23, 24
	Base metal in the shank of eyebars, or through the gross section of pin plates with:	A	23, 24
	<ul style="list-style-type: none"> <li>• Rolled or smoothly ground surfaces</li> <li>• Flame-cut edges</li> </ul>	B	23, 24

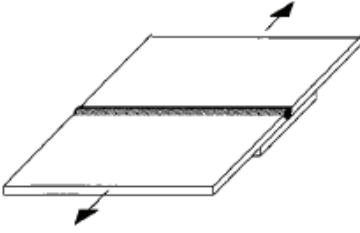
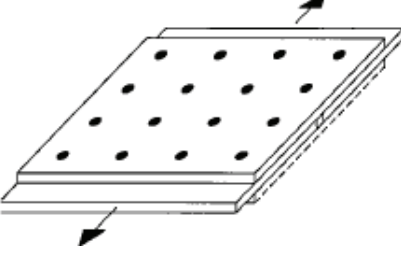
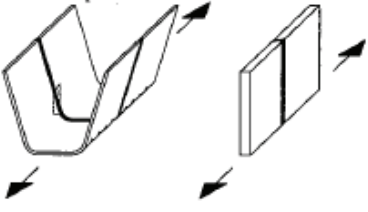
ILLUSTRATIVE EXAMPLE	DETAIL	DESCRIPTION OF CONDITION	DETAIL CATEGORY
	Transverse or longitudinal deck plate splice or rib splice  Single-groove butt weld	(1) Ceramic backing bar. Weld ground flush parallel to stress.	B
		(2) Ceramic backing bar	C
		(3) Permanent backing bar. Backing bar fillet welds shall be continuous if outside of groove or may be intermittent if inside of groove.	D
	Bolted deck plate or rib splice	(4) In unsymmetrical splices, effects of eccentricity shall be considered in calculating stress.	B
	Deck plate or rib splice  Double-groove welds	(5) Plates of similar cross-section with welds ground flush. Weld run-off tabs shall be used and subsequently removed, plate edges to be ground flush in direction of stress.	B
		(6) The height of weld convexity shall not exceed 20% or weld width. Run-off tabs as for (5).	C

**Figure 8.1.41** AASHTO LRFD Bridge Design Specifications, 3<sup>rd</sup> Edition, with 2005 Interim Revisions, Table 6.6.1.2.3-1 - Fatigue Categories of Bridge Details, continued

SECTION 8: Inspection and Evaluation of Common Steel Superstructures  
 TOPIC 8.1: Fatigue and Fracture in Steel Bridges

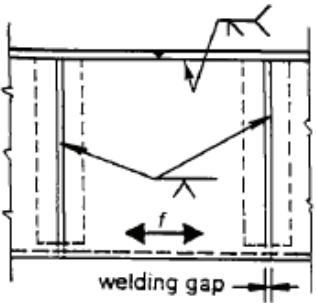
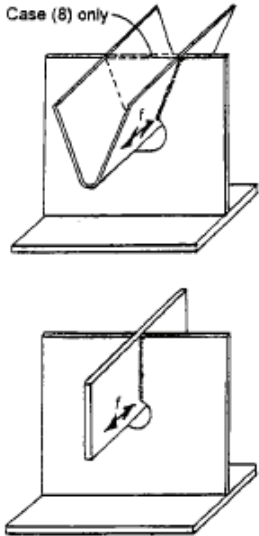
ILLUSTRATIVE EXAMPLE	DETAIL	DESCRIPTION OF CONDITION	DETAIL CATEGORY
	<p>Welded rib "window" field splice</p> <p>Single groove butt weld</p>	<p>(7) Permanent backing bar for rib splice</p> <p>Welding gap &gt; rib wall thickness</p> <p><math>f</math> = axial stress range in bottom of rib</p>	<p>D</p>
	<p>Rib wall at rib/floorbeam intersection</p> <p>Fillet welds between rib and floorbeam web</p>	<p>(8) Closed rib with internal diaphragm inside the rib or open rib</p> <p><math>f</math> = axial stress range in rib wall at the lower end of rib/floorbeam weld</p> <p>(9) Closed rib, no internal diaphragm inside of rib</p> <p><math>f = f_1 + f_2</math></p> <p><math>f_1</math> = axial stress range in rib wall</p> <p><math>f_2</math> = local bending stress range in rib wall due to out-of-plane bending caused by rib-floorbeam interaction, obtained from a rational analysis</p>	<p>C</p> <p>C</p>

**Figure 8.1.41** AASHTO LRFD Bridge Design Specifications, 3<sup>rd</sup> Edition, with 2005 Interim Revisions, Table 6.6.1.2.3-1 - Fatigue Categories of Bridge Details, continued

SECTION 8: Inspection and Evaluation of Common Steel Superstructures  
 TOPIC 8.1: Fatigue and Fracture in Steel Bridges

ILLUSTRATIVE EXAMPLE	DETAIL	DESCRIPTION OF CONDITION	DETAIL CATEGORY
 <p>Case (10) only</p>	<p>Floorbeam web at rib/floorbeam intersection</p> <p>Fillet welds between rib and floorbeam web and between rib and internal diaphragm</p>	<p>(10) With internal diaphragm inside of closed rib, or open rib</p> <p><math>f</math> = axial stress range component in floorbeam web perpendicular to weld = <math>f_1 + f_2</math></p> <p><math>f_1</math> = axial stress range in web</p> <p><math>f_2</math> = bending stress range in web due to out-of-plane bending caused by rib rotation at support</p> <p>Both stresses <math>f_1</math> and <math>f_2</math> to be obtained from a rational analysis</p>	<p>Lesser of C or Eq.6.6.1.2.5-3</p> <p>C for combination fillet-groove welds</p>
		<p>(11) No internal diaphragm inside of closed rib</p> <p><math>f = f_1 + f_2</math></p> <p><math>f</math> = interaction stress range between the "tooth" of the floorbeam web and the rib wall obtained from a rational analysis</p> <p><math>f_2</math> as defined for (10)</p>	<p>C</p>
	<p>Deck plate at the connection to floorbeam web</p>	<p>(12) <math>f</math> = axial stress range in the deck plate at the deck/floorbeam weld</p>	<p>E</p>

Figure 8.1.41 AASHTO LRFD Bridge Design Specifications, 3<sup>rd</sup> Edition, with 2005 Interim Revisions, Table 6.6.1.2.3-1 - Fatigue Categories of Bridge Details, continued

### 8.1.6

#### **Fracture Critical Bridge Types**

The following is a list of steel bridge superstructures which are susceptible to fatigue cracking and possible failure:

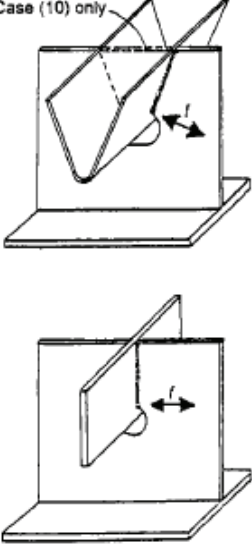
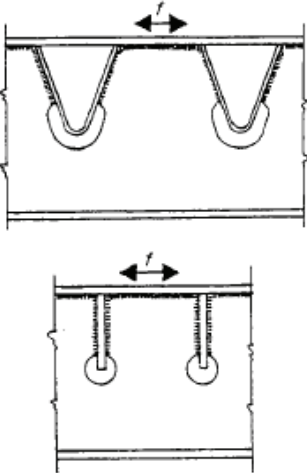
- Suspended spans with two girders (see Topic 8.3)
- Bar-chain suspension bridge with two eyebars per panel (see Topic 8.7)
- Welded tied arches with box shaped tie girder (see Topic 8.8)
- Simple span truss with two eyebars or single member between panel points (see Topic 8.6)
- Simple span single welded box girders with details such as termination of longitudinal stiffeners or gusset plate (see Topic 8.5)
- Simple span two-girder bridges with welded partial length cover plates on the bottom flange (see Topic 8.3)
- Continuous span two-girder system with cantilever and suspension link arrangement and welded partial length cover plates (see Topic 8.3)
- Simple span two-girder system with lateral bracing connected to horizontal gusset plates which are attached to webs (see Topic 8.3)
- Single welded I-girder or box girder pier cap with bridge girders and stringers attached by welding (see Topic 10.2)

Fatigue cracks can develop in steel bridges as a result of repeated loading. Generally, the stress range, number of cycles and type of detail are the most important factors that influence fatigue cracking. Recognizing and understanding the behavior of connections and details is crucial if the inspector is to properly inspect FCMs. Connections and details are often the locations of highest stress concentrations.

### 8.1.7

#### **Fracture Criticality**

Cracks and fractures have occurred in a large number of steel bridges. A report, *Manual for Inspecting Bridges for Fatigue Damage Conditions*, was prepared in 1990 under the support of the Pennsylvania Department of Transportation and the Federal Highway Administration to aid in the inspection of bridges. It summarizes the basic information on fatigue strength of bridge details and contains examples and illustrations of fatigue damage in welded, bolted, and riveted structures. A number of case histories are contained in *Fatigue and Fracture in Steel Bridges - Case Studies*, by John W. Fisher. *Fatigue Cracking of Steel Bridge Structures*, published by the Federal Highway Administration (FHWA) in March 1990, also contains valuable case studies of actual bridges. These three publications are listed in the Bibliography.

There are many factors which influence the fracture criticality of a bridge with FCMs, including:

- The degree of redundancy
- The live load member stress
- The propensity of the material to crack or fracture

- The condition of specific FCMs
- The existence of fatigue prone design details
- The previous number and size of loads
- The predicted number and size of loads

### Details and Defects

Low fatigue strength details, such as cover-plated beams and welded web and flange gusset plates, should be carefully inspected on bridges that have experienced large numbers of stress cycles (see Figure 8.1.42).

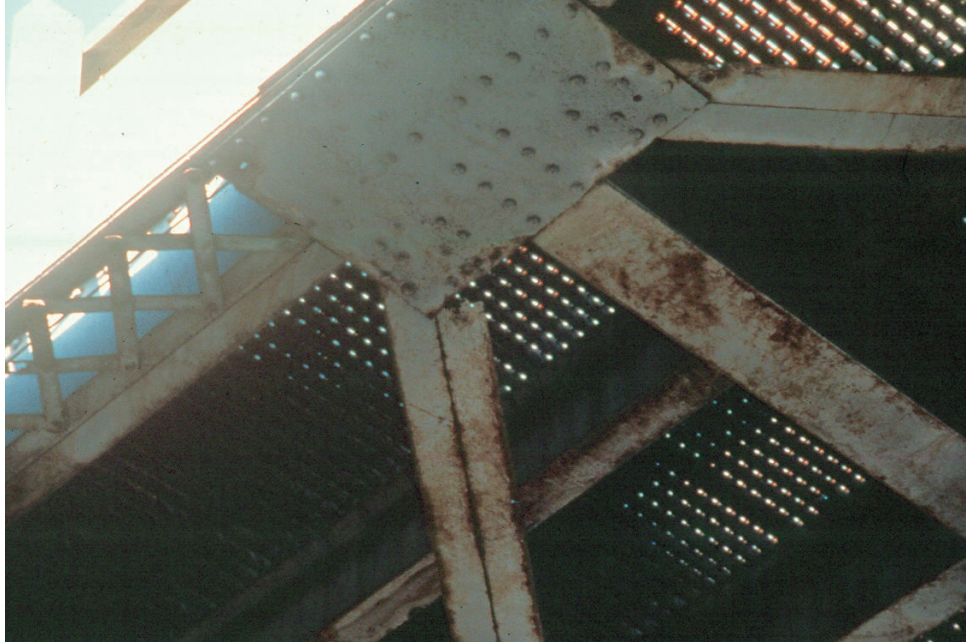

**Figure 8.1.42** Gusset Plate

### Initial Defects

Initial defects, in many cases, are cracks resulting from poor quality welds between attachments and base metal (see Figure 8.1.43). Many of these cracks occurred because the groove-welded element was considered a “secondary” attachment with no established weld quality criteria (e.g., splices in longitudinal web stiffeners). Intersecting welds can provide a path for the crack to travel from secondary members to main members (see Figure 8.1.44).



**Figure 8.1.43** Poor Quality Welds Inside Cross Girder

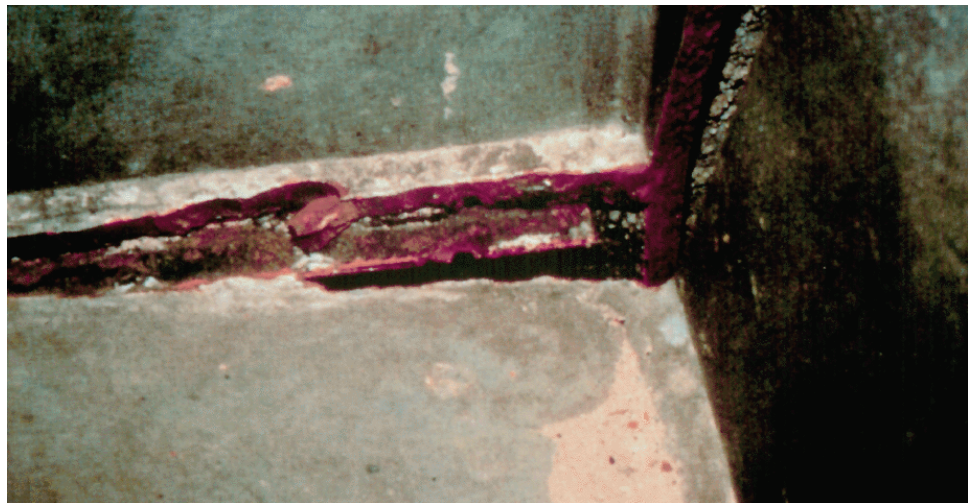

**Figure 8.1.44** Intersecting Welds

Another category of fatigue cracks is related to connection geometry, such as at the end connections of stringers and floorbeams.

## 8.1.8

### **Inspection Procedures and Locations**

While FCMs should be given special attention, care should be taken to assure that the remainder of the bridge or member is not ignored and that it is also inspected thoroughly. Bridge plans and shop drawings for bridges designed after about 1980 should have FCMs clearly identified. If FCMs are not clearly identified, the bridge inspector should use the guidelines previously described in this Topic along with the aid of a structural engineer.

According to the National Bridge Inspection Standards, a fracture critical member inspection is defined as a hands-on inspection of a fracture critical member or member components that may include visual and other nondestructive evaluation. FCM inspections are to be performed at intervals not to exceed twenty-four months. Certain FCMs may require a frequency of less than twenty-four months. Criteria must be established to determine the level and frequency of these inspections based on such factors as age, traffic characteristics, and known deficiencies.

### **Procedures**

#### **Visual**

The inspection of steel bridge members for defects is primarily a visual activity. Most defects in steel bridges are first detected by visual inspection. In order for this to occur, a hands-on inspection, or inspection where the inspector is close enough to touch the area being inspected, is required. More exact visual observations can also be employed by cleaning suspect areas, removing paint when necessary, and using a magnifying unit.

#### **Physical**

Smaller cracks are not likely to be detected visually unless the paint, mill scale, and dirt are removed by carefully cleaning the suspect area. If the confirmation of a possible crack is to be conducted by another person, it is advisable not to disturb the suspected crack area so that re-examination of the actual conditions can be made.

Removal of paint can be done using a wire brush, grinding, or sand blasting, depending on the size and location of the suspected defect. Care should be taken in cleaning when the suspected defect is a crack. When cleaning steel surfaces, any type of cleaning process that would tend to close discontinuities, such as blasting, should be avoided. The use of degreasing spray before and after removal of the paint may help in revealing the defect.

When section loss occurs, use a wire brush, grinder or hammer to remove loose or flaked steel. After the flaked steel is removed, measure the remaining section and compare it to a similar section with no section loss.

The usual and most reliable sign of fatigue cracks is the oxide or rust stains that develop after the paint film has cracked. Experience has shown that cracks have generally propagated to a depth between one-fourth and one-half the plate thickness before the paint film is broken, permitting the oxide to form. This occurs because the paint is more flexible than the underlying steel.

Once the presence of a fatigue crack has been verified, the inspector should examine all other similar locations and details.

### **Advanced Inspection Techniques**

Several advanced techniques are available for steel inspection. Nondestructive methods, described in Topic 13.3.2, include:

- Magnetic particle
- Eddy current
- Dye penetrant
- Ultrasonic testing
- Radiographic testing
- Acoustic emission
- Accelerometers
- Corrosion sensors
- Smart paint 1
- Smart paint 2
- Computer tomography
- Robotic inspection
- Strain measurements
- Vibration measurements
- Magnetic flux leakage
- Measurement of loads
- Measurement of stress ranges

Other methods, described in Topic 13.3.3, include:

- Brinell hardness test
- Charpy impact test
- Chemical analysis
- Tensile strength

### **Inspection of Details**

Fracture critical member inspection should focus on those details that are most susceptible to fatigue problems.

Of all the details, those of AASHTO fatigue Categories E and E' are the most susceptible to fatigue crack growth. If Category E or E' details are found on a FCM, they should be carefully inspected during each inspection and their presence clearly documented in the inspection report.

### **Recordkeeping and Documentation**

The consequences of deficiencies on bridges with FCMs can be very serious. The ability to verify a defect at the bridge site or to correctly evaluate it in the office will depend on the proper recording and documenting of field conditions. Since many defects become obvious only as time passes, complete, clear, and concise recordkeeping provides a valuable reference for comparison in future bridge inspections.



When a deficiency is encountered in a FCM, all relevant information should be recorded carefully and thoroughly, including:

- Method of inspection: visual, physical or advanced (see Topics 2.3 and 13.3)
- The date the deficiency was detected, confirmed, and re-examined
- The type of deficiency, such as cracks, notches, nicks, or gouges, defects in welds, excessive corrosion, or apparent distortion, mislocation, or misalignment of the member
- The general location of the deficiency, such as “at Panel Point L5 of the downstream truss” or “at the lower end of connection plate of Floorbeam No. 4 to the north girder of the eastbound bridge”
- Detailed sketches of the location, shape, and size of the deficiency; extra care should be given to determine the location of the ends of cracks
- The dimensions and details of the member containing the deficiency
- Any noticeable conditions at cracks when vehicles traverse the bridge, such as opening and closing of the crack or visible distortion of the local area
- Any changes in shape or condition of adjacent elements or members
- The presence of corrosion or the accumulation of dirt and debris at the general location of the deficiency
- Weather conditions when the deficiency was discovered or inspected

Label the member using paint or other permanent markings: mark the ends of the crack, the date, compare to any previous markings, be sensitive to aesthetics at prominent areas (see Figure 8.1.51). Photograph and sketch the member and the defect.

Refer to Topics 4.3 and 4.4 for general record keeping, documentation and inspection report writing.

### **Recommendations**

When deficiencies are encountered in FCMs, the repair of the condition generally demands a high priority. The defects listed for repair should be listed in order of priority. For example, a crack in a flange is more significant than surface corrosion of the web. There are two general classifications for repairs of FCMs:

Urgent repairs - repairs that are required immediately in order to maintain the life of the structure or to keep the bridge open; these repairs are for bridge-threatening defects

Programmed repairs – may be worked into the normal maintenance schedule; these repairs are for non-threatening deficiencies and activities such as cleaning and painting of structural steel

### **Locations**

#### **Welded Details**

Welded details tend to be less forgiving of small weld discontinuities than riveted details because welds are more sensitive to repeated stresses. Once cracking starts to develop, it can destroy the member base metal as a result of the continuous path provided by the welded connections. Cracking has developed more frequently in

welded bridges because of flaws that escape detection, the use of details less fatigue resistant than assumed in the design, and secondary and displacement induced stresses.

Fatigue cracks can also develop at welded details in the compression regions of steel bridge members. However, when a crack propagates out of the weld tensile-residual-stress zone and into the adjacent compression region, the crack growth usually stops. Because of this, the inspection of welded details in regions of nominal compressive stress is of lower priority than in tension regions.

Effective and intense inspection for fatigue cracks in welded bridges should be performed at several locations.

For main members, inspect the following locations:

- Ends of welded cover plates
- Groove welds in flange plates
- Butt welds in longitudinal stiffeners
- Web plates with cutouts and filler welds
- Intersecting groove welds
- Welded repairs and reinforcement
- Back-up bar splices
- Stress Risers

For connections and attachments, inspect the following locations:

- Cut short flanges
- Coped beam ends
- Blocked flange plates
- Welded rigid connections of cross girders at bents
- Welded flange attachments
- Intersecting welds at gusset plates and diaphragms

### Riveted and Bolted Details

Fatigue cracking can occur at riveted or bolted details, particularly as the result of secondary or displacement-induced stresses, or from assembly tack welds which have not been removed. Framing connections intended to provide only simple support, but by their function tend to resist bending moment, are suspect locations. Fortunately, crack growth is often inhibited by multiple element members, i.e., internal redundancy.

Most riveted bridges were constructed prior to the 1960's when bolted connections became common. Because of their age and the number of stress cycles already experienced, the close inspection of riveted members and connections in bridges with high truck traffic volume is necessary. In general, the locations where fatigue cracks develop in riveted bridges are similar to those in welded bridges:

- Cracking and prying of rivets/bolts at end connections
- End connection angle failure (see Figure 8.1.45)
- Girder webs at floorbeam connections
- Floorbeam connections to girders
- Diaphragm connections to girders
- Cantilever bracket connections to girders
- Truss hangers
- Eyebars
- Tack welds

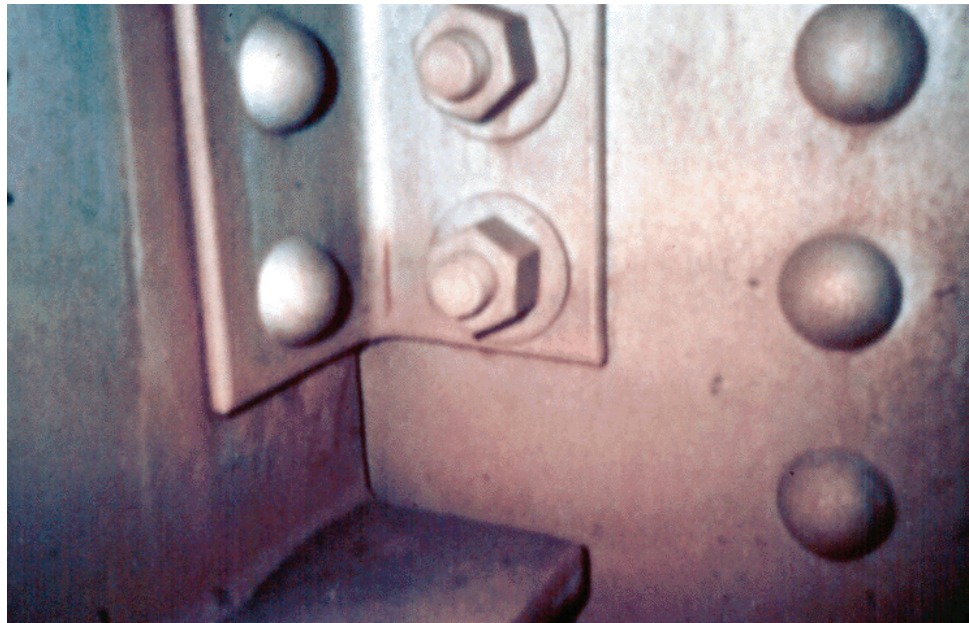

**Figure 8.1.45** Cracked Stringer Connection Angle

### Copes

Coping or cutting away of the flange and portion of the web, may be necessary to connect stringers, floorbeams, diaphragms and the main girders. Copes are often flame cut, resulting in residual tensile stresses along the cut edges, approaching the yield point (see Figure 8.1.46).

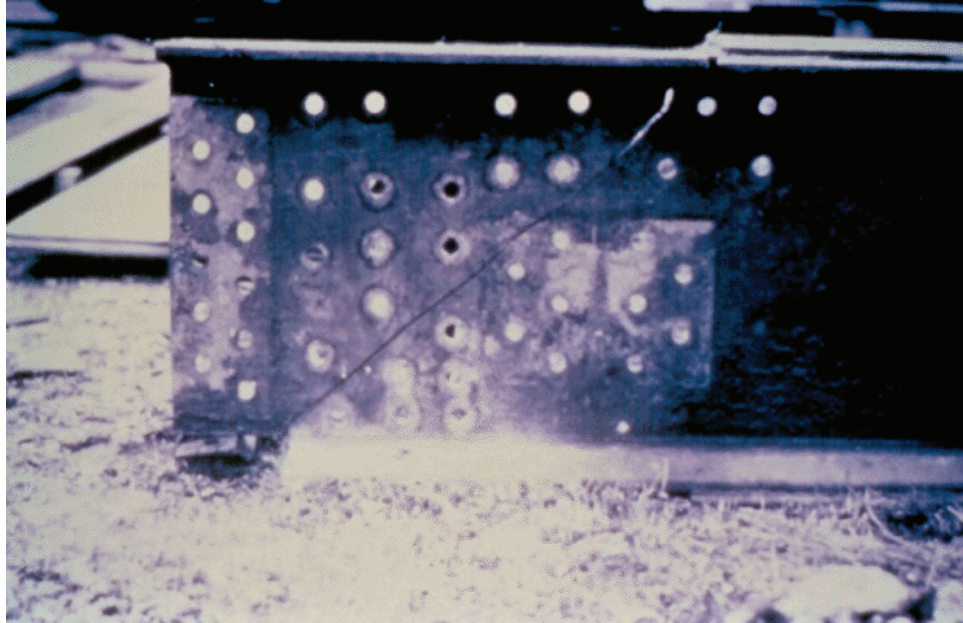

**Figure 8.1.46** Fracture of a Coped Member

### Flange Terminations

It is also common to terminate the flange before the end connection to facilitate fabrication (see Figure 8.1.47). When one or both flanges are removed, as in a blocked flange cut, the web plate has a lower cross section as compared to the entire member. This can increase the stress in the web plate where the flange is terminated by 200 to 300 percent.



**Figure 8.1.47** Flange Termination

### End Restraints

A related type of cracking develops in the end connection angles. End rotation can deform the connection angle out-of-plane. This results in cracking of the angle often at the fillet or the bolt/rivet line (see Figure 8.1.48 and 8.1.49). In some cases, the rivet or bolt heads will crack off if the angle is relatively thick.

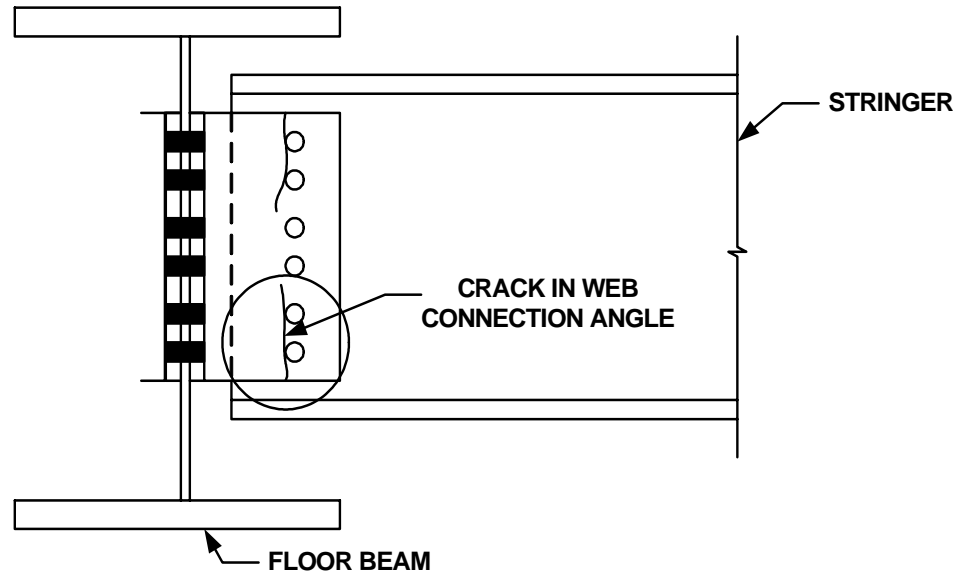

**Figure 8.1.48** Cracked Stringer to Floorbeam Connection Angle

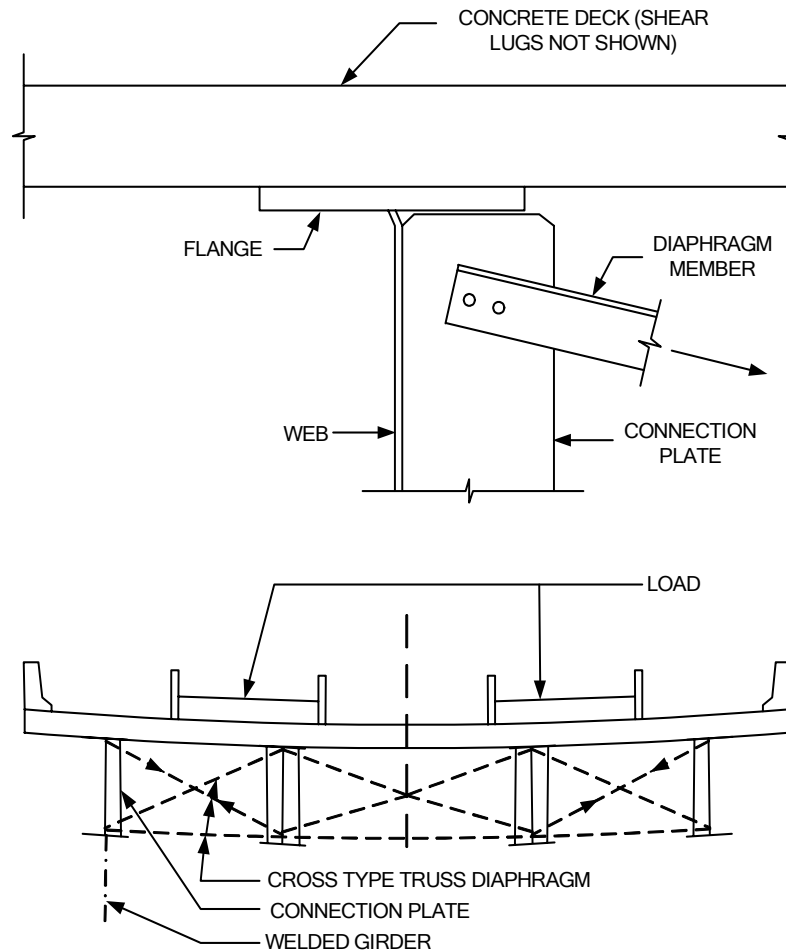

**Figure 8.1.49** Cracked Stringer to Floorbeam Connection Angle

### **Out-of-Plane Distortion**

Deflection of floorbeams or diaphragms can cause out-of-plane distortion in the girder webs. Cracks caused by out-of-plane distortion are not covered in AASHTO Fatigue Categories A - E'. Out-of-plane distortion occurs across a small web gap between the flanges and end of vertical connection plates (see Figure 8.1.50). When cracks form in planes parallel to the stresses between the flanges and end of vertical connection plates they are not typically detrimental to the performance of the structure.

SECTION 8: Inspection and Evaluation of Common Steel Superstructures  
TOPIC 8.1: Fatigue and Fracture in Steel Bridges



**Figure 8.1.50** Out-Of-Plane Distortion in Web Gap at End of Transverse Connection Plate

Two very common instances are in the web gap at unconnected cross-frame connection plates, that is, connection plates which are not attached to the beam or girder flanges, and at similar web gaps at floorbeam connections to main girders.

The problem of distortion-induced fatigue cracking has developed in many types of bridges, including:

- Trusses
- Suspension bridges
- Two-girder bridges
- Multi-beam and multi-girder bridges
- Tied arch bridges
- Box girder bridges

When distortion-induced cracking develops in a bridge, there are usually large numbers of cracks that form before corrective action is taken, because the cyclic stresses are often very high. As a result, many cracks form simultaneously in the structural system (see Figure 8.1.51).

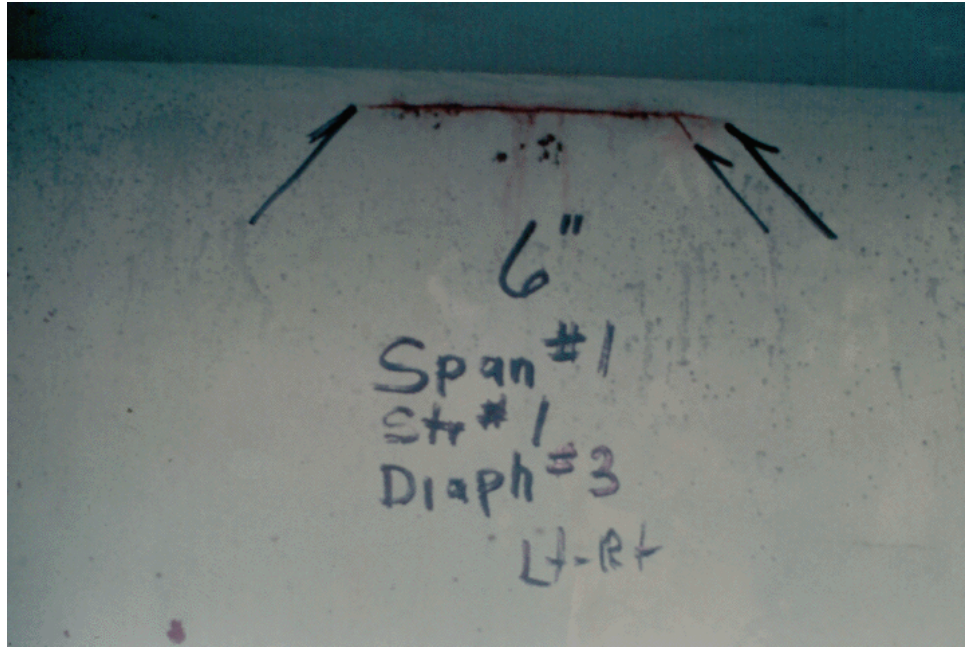

**Figure 8.1.51** Crack Near Top Flange at a Diaphragm Connection Plate which is on the Opposite Side of the Web

For out-of-plane distortion, inspect the following locations:

- Girder webs at floorbeam and diaphragm connections (see Figure 8.1.52)
- Ends of diaphragm connection plates in girder bridges
- Box girder webs at diaphragms
- Lateral bracing gusset plates on girder webs at floorbeam connections
- Floorbeam and cantilever bracket connections to girders
- Pin connected hanger plates and fixed pin plates

Once an out-of-plane bending crack is identified, it is extremely important that all similar locations on the structure also be carefully inspected to search for similar damage.

Even though distortion induced cracks are usually parallel to the primary stress direction, they can turn perpendicular. Retrofits such as drilled holes are often used when cracks turn perpendicular to the primary stresses.



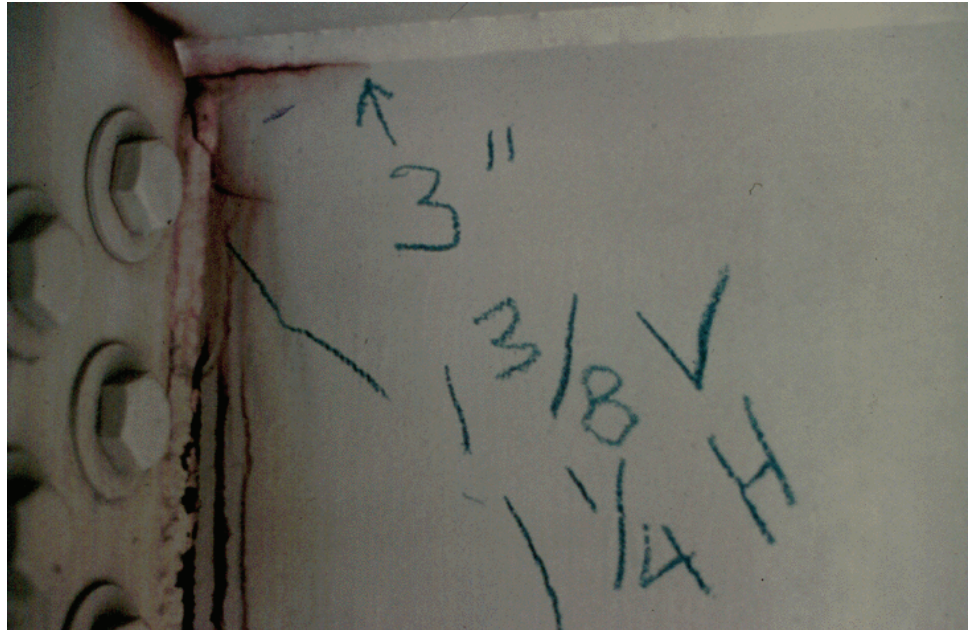

**Figure 8.1.52** Cracks at Top of Floorbeam Connection to Girder

### Cracks Perpendicular to Primary Stress

Cracks perpendicular to primary stress are very serious because all stresses applied to the member will work towards propagating the crack (see Figure 8.1.53). The inspector should report them immediately so that repairs can be performed.

### Cracks Parallel to Primary Stress

Cracks parallel to primary members are less serious than transverse cracks. Cracks parallel to the main direction of stress, do not reduce the capacity load and have less tendency to propagate. These cracks are still important because they can turn perpendicular to the direction of stress at any time (see Figure 8.1.53).

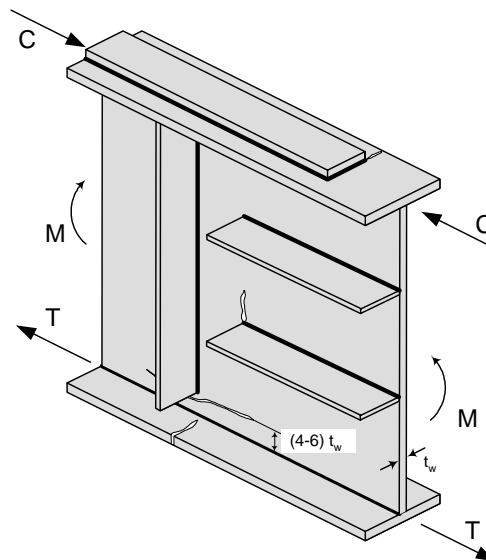

**Figure 8.1.53** Cracks Perpendicular or Parallel to Applied Stress

## **Corrosion**

Corrosion is probably the most common form of defect found on steel bridges. More section loss results from corrosion than from any other cause. However, few bridge failures can be attributed solely to corrosion. Shallow surface corrosion is generally not serious but is quite common when the paint system has failed. Measurable section loss is significant as it may reduce the structural capacity of the member.

Nicks or gouges will often need to be evaluated by the bridge engineer responsible for the rating of the structure because they cause stress concentrations and may result in fatigue cracking. If large, they should be evaluated in a manner similar to section loss occurring due to corrosion.

### **8.1.9**

#### **Evaluation**

State and federal rating guidelines systems have been developed in order to provide continuity in the inspection of steel superstructures. The two major rating guideline systems currently in use are the FHWA's *Recording and Coding Guide for the Structural Inventory and Appraisal of the Nation's Bridges* used for the National Bridge Inventory (NBI) component rating method and the AASHTO element level condition state assessment method using the *AASHTO Guide for Commonly Recognized (CoRe) Structural Elements*.

#### **NBI Rating Guidelines and Element Level Condition State Assessment**

Refer to Topics 5.3, 8.2 through 8.9 10.1 and 10.2 for specific rating guidelines for the various types of steel bridge components.

SECTION 8: Inspection and Evaluation of Common Steel Superstructures  
TOPIC 8.1: Fatigue and Fracture in Steel Bridges

This page intentionally left blank.

# Table of Contents

---

## Section 8 Inspection and Evaluation of Common Steel Superstructures

---

8.2	Rolled Steel Multi-beams and Fabricated Steel Multi-girders.....	8.2.1
8.2.1	Introduction.....	8.2.1
8.2.2	Design Characteristics.....	8.2.1
	Rolled Multi-beam.....	8.2.1
	Fabricated Multi-girder .....	8.2.3
	Haunched Girder Design .....	8.2.7
	Function of Stiffeners .....	8.2.8
	Primary and Secondary Members .....	8.2.9
	Fatigue Prone Details .....	8.2.10
	Fracture Critical Areas .....	8.2.11
8.2.3	Overview of Common Defects .....	8.2.11
8.2.4	Inspection Procedures and Locations.....	8.2.11
	Procedures .....	8.2.11
	Visual .....	8.2.11
	Physical.....	8.2.11
	Advanced Inspection Techniques .....	8.2.12
	Locations .....	8.2.13
	Bearing Areas.....	8.2.13
	Shear Zones.....	8.2.13
	Flexure Zones.....	8.2.13
	Secondary Members.....	8.2.15
	Areas that Trap Water and Debris.....	8.2.16
	Areas Exposed to Traffic .....	8.2.17
	Fatigue Prone Details.....	8.2.18
	Fracture Critical Members .....	8.2.20
	Out-of-plane Distortion.....	8.2.20
	Girder Webs at Diaphragm Connections .....	8.2.20

SECTION 8: Inspection and Evaluation of Common Steel Superstructures  
TOPIC 8.2: Rolled Steel Multi-beams and Fabricated Steel Multi-girders

	Ends of Diaphragm Connection Plates in Girder Bridges.....	8.2.22
	Lateral Gussets on Plate Girder Webs at Connections .....	8.2.23
8.2.5	Evaluation .....	8.2.23
	NBI Rating Guidelines .....	8.2.23
	Element Level Condition State Assessment.....	8.2.24

# Topic 8.2 Rolled Steel Multi-beams and Fabricated Steel Multi-girders

## 8.2.1

---

### Introduction

The two basic steel superstructure types, rolled steel multi-beams and fabricated steel multi-girders, have similar characteristics; however, there are some primary differences that make each superstructure type unique.

One of the simplest differences is the terminology. Although many designers and inspectors use the terms “beam” and “girder” interchangeably, there is a difference. In steel fabrication, the word "beam" refers to rolled shapes, while the word "girder" refers to fabricated members. Girders are fabricated from web and flange plates.

Rolled beams are generally “compact” sections that satisfy ratios for the flange and web thicknesses to prevent buckling. Rolled beams come in a number of different sizes with each size having specific dimensions for the width and thickness for both the flange and web. These dimensions are standard and can be found in a number of publications, such as the *Manual for Steel Construction, Load and Resistance Factor Design* published by the American Institute of Steel Construction, Inc. Also, rolled beams may have bearing stiffeners but no intermediate stiffeners.

Fabricated girders are different from rolled beams in that they are custom made for specific bridge site conditions. The width and thickness of the flanges and webs can be varied to the necessary dimensions to optimize the design. Fabricated girders generally have bearing stiffeners and intermediate stiffeners.

## 8.2.2

---

### Design Characteristics

#### Rolled Multi-beam

The steel rolled multi-beam bridge is a configuration of three or more parallel rolled beams with a deck placed on top of the beams. The most common use of this superstructure type is for simple spans, with span lengths from 9 to 15 m (30 to 50 feet) (see Figure 8.2.1). Continuous span designs have also been used, some of which incorporate pin and hanger connections (see Figure 8.2.2). Rolled beams are manufactured in structural rolling mills from one piece of steel (i.e., the flanges and web are manufactured as an integral unit). Rolled beams in the past were generally available no deeper than 915 mm (36 inches) in depth but are now available from some mills as deep as 1200 mm (48 inches).



**Figure 8.2.1** Simple Span Rolled Multi-beam Bridge



**Figure 8.2.2** Continuous Span Rolled Multi-beam Bridge with Pin & Hanger

In the past, a common method of economically increasing the capacity of a rolled multi-beam bridge was to weld partial length cover plates to the flanges (see Figure 8.2.3). The cover plates increased a beam's bending strength. This practice also creates a fatigue prone detail in the tension flange, which may lead to cracking. The cover plates are attached by riveting or welding. Fatigue cracking occurs in the beam flanges at the ends of partial length cover plates.



**Figure 8.2.3** Rolled Multi-beam Bridge with a Cover Plate

**Fabricated Multi-girder**

The steel fabricated multi-girder bridge is similar to the rolled multi-beam bridge in appearance. However, fabricated girders are larger than those that could be provided by the rolling mills. Older fabricated multi-girders are riveted or bolted built-up members consisting of angles and plates (see Figure 8.2.4). In a riveted or bolted built-up member, the angles are considered part of the flange. Today's fabricated multi-girders are usually welded plate members (see Figure 8.2.5).

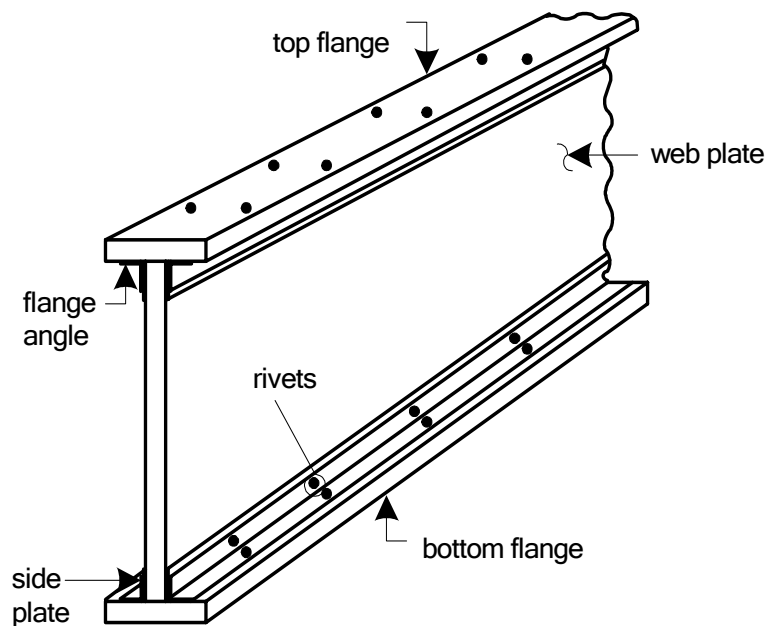

**Figure 8.2.4** Built-up Riveted Plate Girder



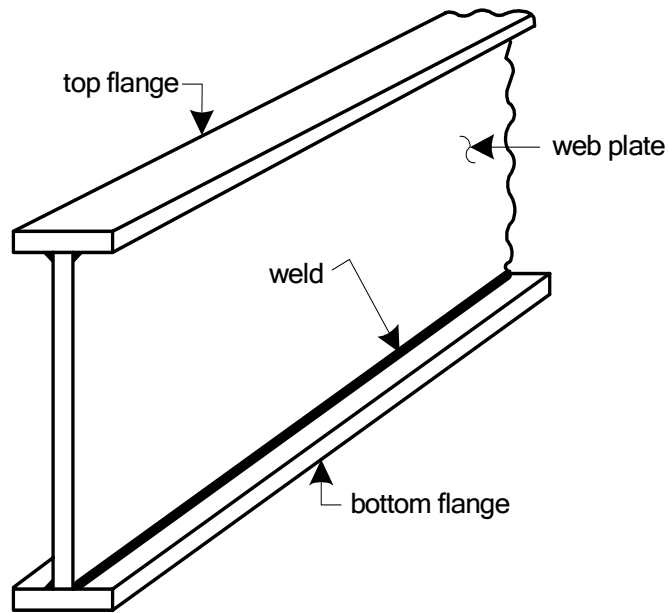

**Figure 8.2.5** Welded Plate Girder

This bridge type can be found in single span (see Figure 8.2.6), multiple span, and continuous span designs (see Figure 8.2.7), and it is widely used when curved bridges are required (see Figure 8.2.8). Continuous welded multi-girders have been built for spans of over 152 m (500 feet). Pin and hanger connections are also found in multi-girder construction (see Figure 8.2.9).



**Figure 8.2.6** Single Span Fabricated Multi-girder Bridge



**Figure 8.2.7** Continuous Span Fabricated Multi-girder Bridge



**Figure 8.2.8** Curved Fabricated Multi-girder Bridge

Fabricated multi-girder bridges have three or more primary load paths (girders). Two-girder bridge systems are discussed in Topic 8.3.



**Figure 8.2.9** Fabricated Multi-girder Bridge with Pin & Hanger Connection

Sometimes, both types of superstructure, rolled steel beams and fabricated steel girders can be used on the same bridge (see Figure 8.2.10). The shorter approach spans are rolled beams while the longer main span utilizes fabricated girders.



**Figure 8.2.10** Combination Rolled Beams and Fabricated Girders

**Haunched Girder Design** In continuous girder designs, additional girder strength is required in negative moment regions. This is accomplished through a method called haunching. Haunching is the increasing of the web depth for a specified portion of the girder. The regions above intermediate supports (i.e. piers and bents) have negative moments larger than the adjacent positive moments. Typically, the girder depth used at the positive moment regions is not sufficient enough to resist these moments, so the web depth needs to be increased. (See Topic P.2 on Moments and Shear) However, instead of increasing the depth for the full length of the girder, the girder is haunched at the intermediate supports.

Three methods have been used to haunch girders.

To haunch a riveted plate girder, a larger web plate size is used in the region required.

To haunch a rolled beam, the bottom flange is separated from the web and an insert plate of the required depth is welded in place (see Figure 8.2.11).

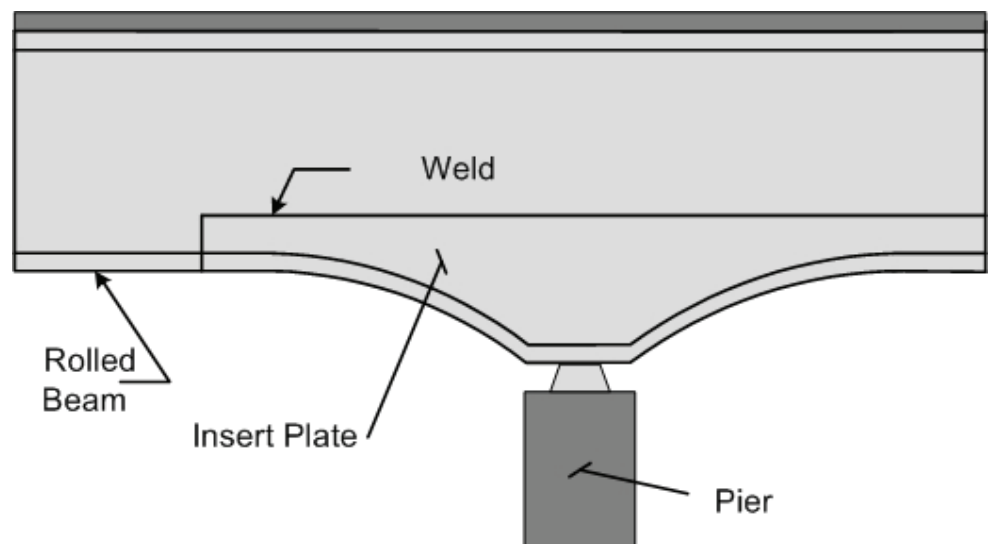

**Figure 8.2.11** Web Insert Plate for Multi-beam

A fabricated variable depth girder is the method used today (see Figure 8.2.12). The web plate is simply fabricated to the required depth. The top and bottom flange plates are then welded to the web plate.



**Figure 8.2.12** Fabricated Variable Depth Girder Bridge

### **Function of Stiffeners**

As fabricated girders become longer, the depth of the web plate increases, and it becomes susceptible to web buckling (i.e., failure of the web due to compressive or shear stresses). Bridge designers prevent this from occurring by increasing the web thickness or by reinforcing the web with steel stiffener plates. Stiffeners can be either transverse (vertical) or longitudinal (horizontal). They can be placed on one or both sides of the web. The stiffeners limit the unsupported length of the web, which results in increased stability of the girder.

**Primary and Secondary Members**

The primary members of a rolled multi-beam bridge are the rolled beams, and the secondary members are the diaphragms (see Figure 8.2.13). Intermediate and end diaphragms are provided to stabilize the beams during construction and to help distribute the live load more evenly to the rolled beams. Diaphragms may or may not be present on the multi-beam bridge.



**Figure 8.2.13** Rolled Beam (Primary Member) with Diaphragm (Secondary Member)

The primary members of a fabricated multi-girder bridge are the fabricated girders, as well as the diaphragms on a curved bridge. In the case of a curved structure, the diaphragms are designed to withstand the torsional loading attributed to curved structures and therefore, are also considered primary members (see Figure 8.2.14).

On straight multi-girder bridges, diaphragms are considered secondary members. Similar to rolled beam bridges, diaphragms are provided to stabilize the girders during construction and to help distribute secondary live load (see Figure 8.2.15). Diaphragms can be rolled shapes (e.g., I-beams and channels) or they can be cross frames constructed from angles, tee shapes, and plates. They are usually attached to transverse web stiffeners which are normally referred to as connection plates. On older bridges, secondary members also include lateral bracing. Current design specifications discourage the use of lateral bracing. This is due to connections for lateral bracing being fatigue-prone.



**Figure 8.2.14** Curved Multi-girder Bridge



**Figure 8.2.15** Straight Multi-girder Bridge

### **Fatigue Prone Details**

Some common areas for fatigue prone details are:

- Welded cover plates on the tension flange
- Attachment welds in the tension zone
- Longitudinal and transverse stiffeners (intersections of welds)
- Fatigue cracks can also occur due to web-gap distortion and out-of-plane distortion
- Welded, bolted, or riveted connections

Inspection of these areas will be discussed further detail in Topic 8.2.4.

**Fracture Critical Areas** Both rolled multi-beam bridges and steel multi-girder bridges consist of a minimum of three beams or girders and have load path redundancy. Since load path redundancy is achieved, these bridge types do not contain any fracture critical members.

### 8.2.3

#### Overview of Common Defects

Common defects that occur on steel multi-beam and fabricated multi-girder bridges are:

- Paint failures
- Corrosion
- Fatigue cracking
- Collision damage
- Overloads
- Heat damage

See Topic 2.3 for a detailed presentation of the properties of steel, types and causes of steel deterioration, and the examination of steel. Refer to Topic 8.1 for Fatigue and Fracture in Steel Bridges.

### 8.2.4

#### Inspection Procedures and Locations

Inspection procedures to determine other causes of steel deterioration are discussed in detail in Topic 2.3.8.

##### Procedures

##### Visual

The inspection of steel bridge members for defects is primarily a visual activity.

Most defects in steel bridges are first detected by visual inspection. In order for this to occur, a hands-on inspection, or inspection where the inspector is close enough to touch the area being inspected, is typically required. More exact visual observations can also be employed using a magnifying unit after cleaning the paint from the suspect area.

##### Physical

Removal of paint can be done using a wire brush, grinding, or sand blasting, depending on the size and location of the suspected defect. Care should be taken in cleaning when the suspected defect is a crack. When cleaning steel surfaces, any type of cleaning process that would tend to close discontinuities, such as blasting, should be avoided. The use of degreasing spray before and after removal of the paint may help in revealing the defect.

When section loss occurs, use a wire brush, grinder or hammer to remove loose or flaked steel. After the flaked steel is removed, measure the remaining section and



compare it to a similar section with no section loss.

The usual and most reliable sign of fatigue cracks is the oxide or rust stains that develop after the paint film has cracked. Experience has shown that cracks have generally propagated to a depth between one-fourth and one-half the plate thickness before the paint film is broken, permitting the oxide to form. This occurs because the paint is more flexible than the underlying steel.

Smaller cracks are not likely to be detected visually unless the paint, mill scale, and dirt are removed by carefully cleaning the suspect area. If the confirmation of a possible crack is to be conducted by another person, it is advisable not to disturb the suspected crack area so that re-examination of the actual conditions can be made.

Once the presence of a crack has been verified, the inspector should examine all other similar locations and details.

### **Advanced Inspection Techniques**

Several advanced techniques are available for steel inspection. Nondestructive methods, described in Topic 13.3.2, include:

- Acoustic emissions testing
- Computer tomography
- Corrosion sensors
- Smart paint 1
- Smart paint 2
- Dye penetrant
- Magnetic particle
- Radiographic testing
- Robotic inspection
- Ultrasonic testing
- Eddy current

Other methods, described in Topic 13.3.3, include:

- Brinell hardness test
- Charpy impact test
- Chemical analysis
- Tensile strength test

## Locations

### Bearing Areas

Examine the web areas over the supports for cracks, section loss or buckling. If bearing stiffeners, jacking stiffeners and diaphragms are present at the supports inspect them for cracks, section loss and buckling also.

Examine the bearings at each support for corrosion. Check the alignment of each bearing and note any movement. Report any build up of debris surrounding the bearings that may limit the bearing from functioning properly. Check for any bearings that are frozen due to heavy corrosion. See Topic 9.1 for a detailed presentation on the inspection of bearings.

### Shear Zones

Examine the web areas near the supports for any section loss or buckling (see Figure 8.2.16). Shear stresses are greatest near the supports. Therefore, the condition of the web is more critical near the supports than at mid-span. Also investigate the web for buckling due to overloads. If girders have been haunched by the use of insert plates, check the weld between the web and the insert plate.



**Figure 8.2.16** Corroded Shear Zone on a Rolled Multi-beam Bridge

### Flexure Zones

The flexure zone of each beam/girder includes the entire length between the supports (see Figures 8.2.17 and 8.2.18). Investigate the tension and compression flanges for corrosion, loss of section, cracks, dings, and gouges. Check the flanges in high stress areas for bending or flexure-related damage. Examine the compression flange for local buckling and, although it is uncommon, for elongation or fracture of the tension flange. On continuous spans, the beam/girder over the

SECTION 8: Inspection and Evaluation of Common Steel Superstructures  
TOPIC 8.2: Rolled Steel Multi-beams and Fabricated Steel Multi-girders

intermediate supports have high flexural stresses due to negative moment (see Figures 8.2.19 and 8.2.20). If welded cover plates are present, check carefully at the ends of the cover plates for cracks.

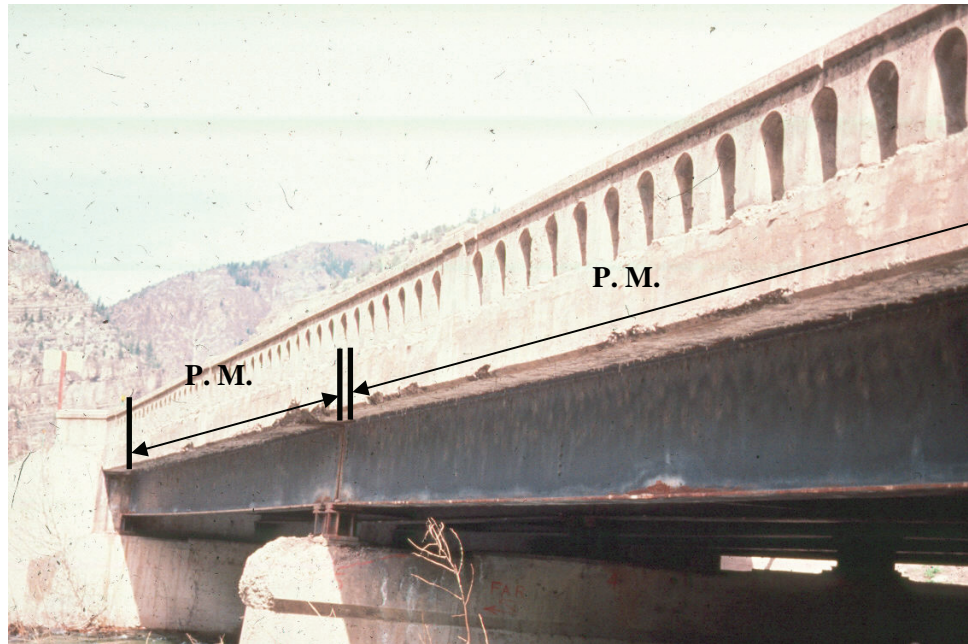

**Figure 8.2.17** Flexural Zone on a Simple Rolled Multi-beam Bridge is Entire Length of Beams Between Supports

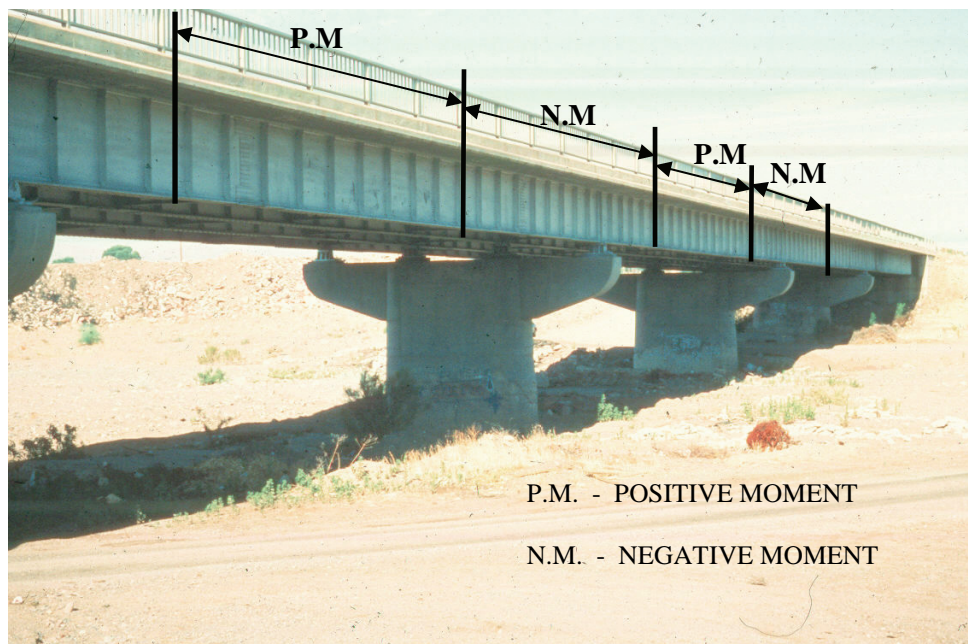

**Figure 8.2.18** Flexural Zone on a Fabricated Multi-girder Bridge

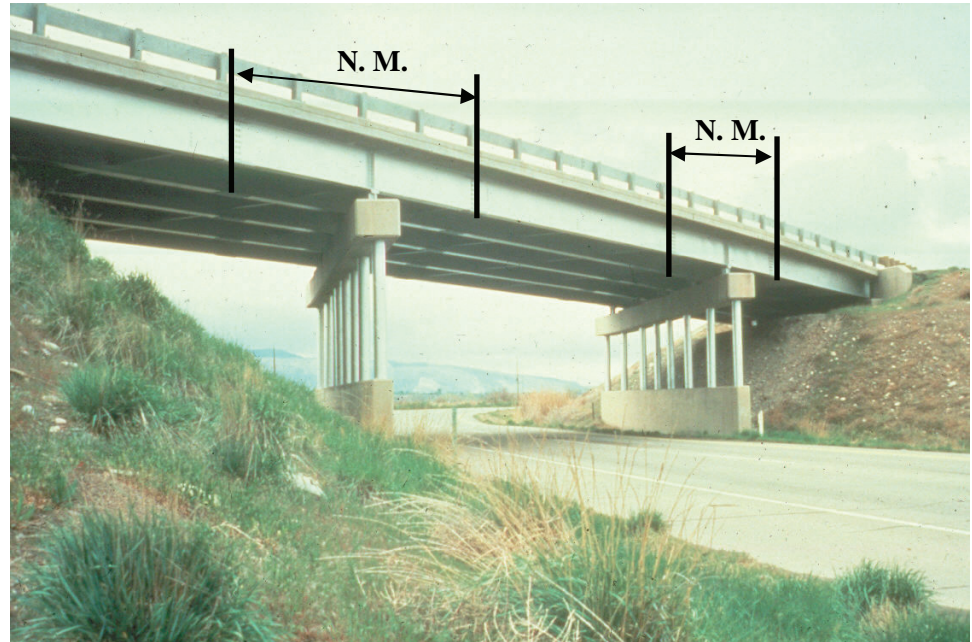

**Figure 8.2.19** Negative Moment Region on a Continuous Rolled Multi-beam Bridge

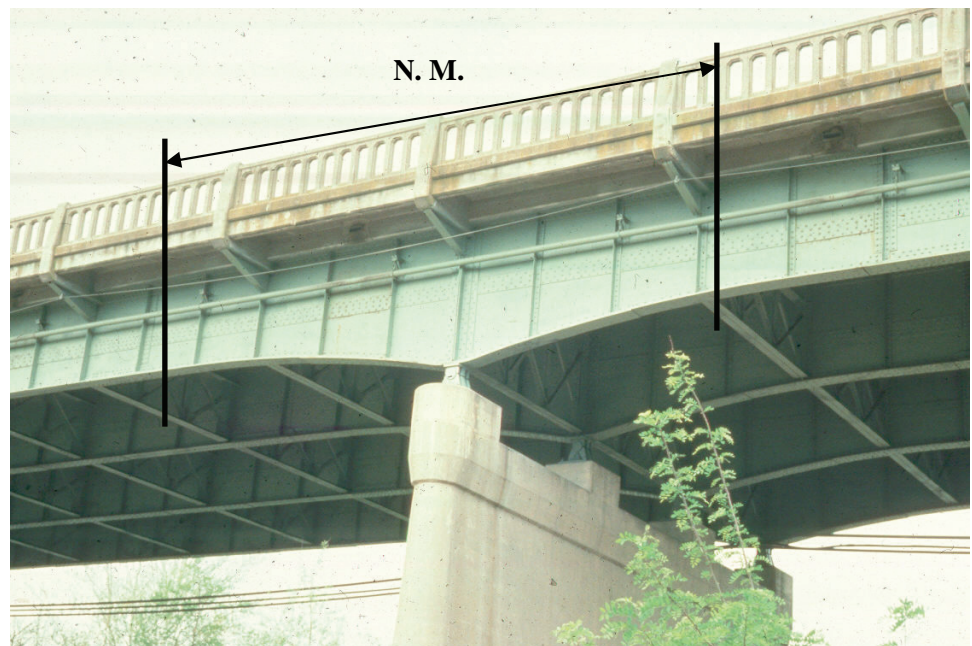

**Figure 8.2.20** Negative Moment Region on a Continuous Fabricated Multi-girder Bridge

### Secondary Members

Examine the diaphragm and bracing connections for loose fasteners or cracked welds (see Figures 8.2.21 and 8.2.22). This problem is most common on skewed bridges, and it has also been observed on bridges with a high frequency of combination truck loads. Check horizontal connection plates, which can trap debris and moisture and are susceptible to a high degree of corrosion and

deterioration. Check for distorted members. Distorted secondary members may be an indication the primary members may be overstressed or the substructure may be experiencing differential settlement.



**Figure 8.2.21** End Diaphragm



**Figure 8.2.22** Intermediate Diaphragm

### **Areas That Trap Water and Debris**

Check horizontal surfaces that can trap debris and moisture which are susceptible to a high degree of corrosion and deterioration. Areas that trap water and debris can result in active corrosion cells and excessive loss in section. This can result in

notches susceptible to fatigue or perforation and loss of section.

On multi-beam and fabricated multi-girder bridges check:

- Along the bottom flanges
- Pockets created by diaphragm connections
- Lateral bracing gusset plates
- Areas exposed to drainage runoff

#### **Areas Exposed to Traffic**

Check underneath the bridge for collision damage to the main girders and bracing if the bridge crosses over a highway, railway, or navigable channel. Document any cracks, section loss, or distortion found (see Figures 8.2.23 and 8.2.24).

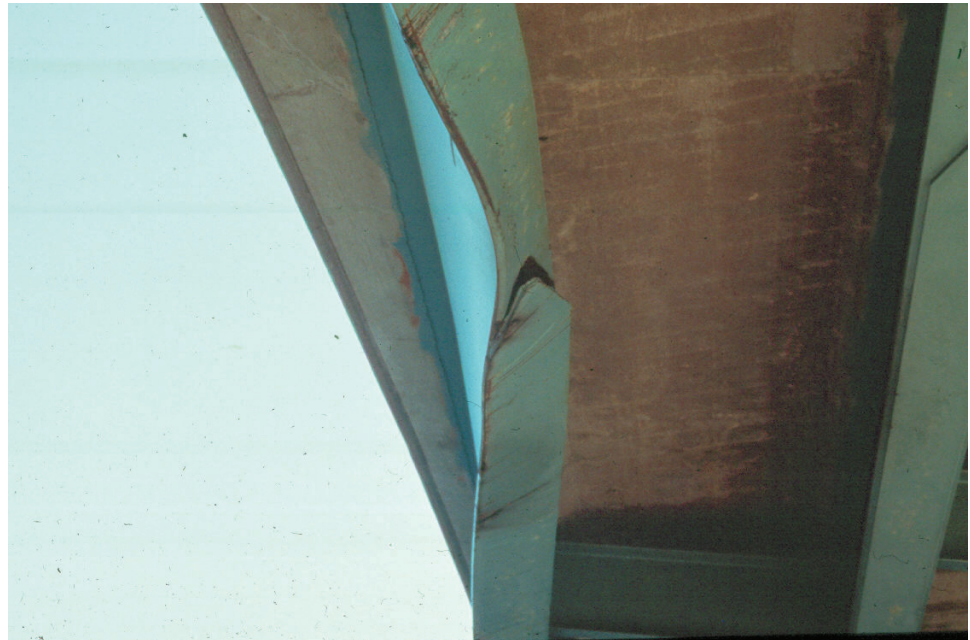

**Figure 8.2.23** Collision Damage on a Rolled Multi-beam Bridge



**Figure 8.2.24** Collision Damage on a Fabricated Multi-girder Bridge

### **Fatigue Prone Details**

Dirt and debris traps can result in active corrosion cells when water and salt are present. These corrosion cells can lead to excessive section loss. This corrosion can result in notches that are susceptible to fatigue or perforation.

If the structure has been painted, breaks in the paint accompanied by rust staining indicate the possible existence of a fatigue crack. Investigate the areas surrounding field splice plates on the tension flange (see Figure 8.2.25). The suspected crack area should be cleaned to determine the existence of a crack and its extent. If a crack with rust staining exists in the paint, the fatigue cracks in the steel can already be up to 6 mm (1/4 inch) deep in the beam flange. Check any attachment welds located in the superstructure tension zones, such as traffic safety features, lighting brackets, utility attachments, catwalks and signs (see Figure 8.2.26).

Check web stiffener welds, welded web/flange splices and intersecting welds. Welds are considered to be intersecting if they run through each other, overlap, touch or are within 6 mm (1/4 inch) from each other. Intersecting welds or narrow gaps between perpendicular welds are stress risers and can lead to crack initiation. The restraining effect of the intersecting plate elements cause large residual stresses during the cooling process of fabrication. These residual stresses can lead to cracking and reduced fatigue strength. To avoid intersecting welds, welds should terminate short of the intersection by at least 1/4". In most cases, it is desirable to allow the longitudinal weld (parallel with the applied stress) to be continuous. This avoids Category E type detail at the weld termination if it is interrupted. The end termination of a transverse weld does not directly affect its fatigue strength and is classified as Category C' for plates.

SECTION 8: Inspection and Evaluation of Common Steel Superstructures  
TOPIC 8.2: Rolled Steel Multi-beams and Fabricated Steel Multi-girders

If the girder is riveted or bolted, check all rivets and bolts to determine that they are tight and in good condition. Check for cracked or missing bolts, rivets and rivet heads. Also, check the base metal around the bolts and rivets.

Inspect the member for misplaced holes or repaired holes that have been filled with weld material. Check for plug welds which are possible sources of fatigue cracking.

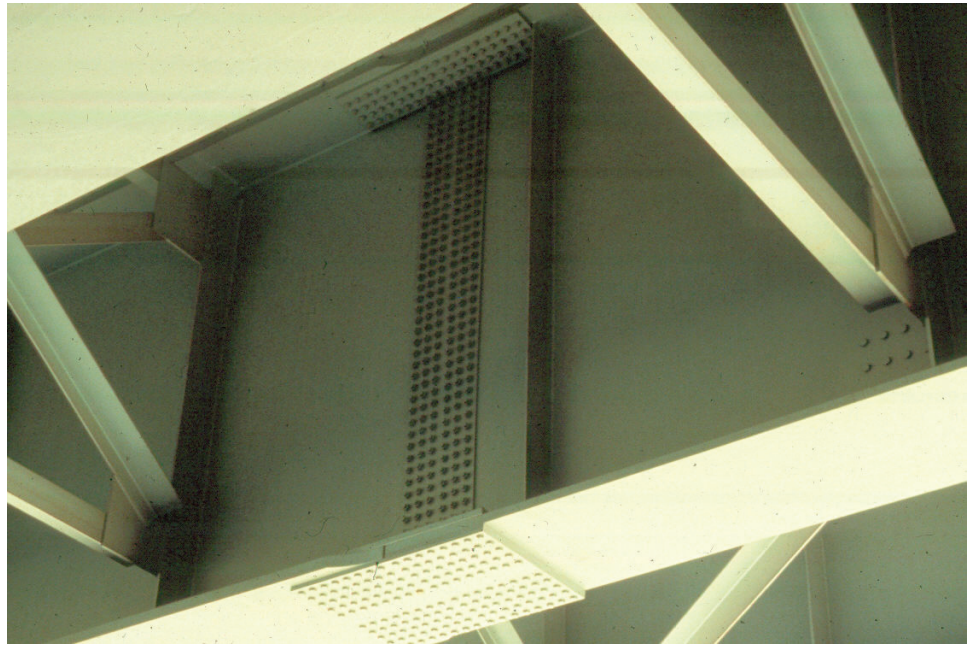

**Figure 8.2.25** Field Splice



**Figure 8.2.26** Welded Attachment in Tension Zone of a Beam



### **Fracture Critical Members**

Both rolled multi-beam bridges and fabricated multi-girder bridges have load path redundancy, and therefore have no fracture critical members.

### **Out-of-plane Distortion**

Out-of-plane distortion can occur in several areas that can lead to web cracks near the flanges of steel bridges. The following are some common areas for out-of-plane distortion.

#### **Girder Webs at Diaphragm Connections**

Diaphragms between multi-girders exert out-of-plane forces to the girder webs through the vertical connection plates. The connection plates are usually sufficient to transmit the forces to the girders. The structural details at the ends of the connection plates sometimes are inadequate to accommodate the deflections and rotations.

Connection plate at top flange - One type of connection detail which has incurred a large number of fatigue cracks is the end of diaphragm connection plates which are not attached to the top tension flange of continuous girder bridges. While the top flange is rigidly embedded in the bridge deck slab, and the connection plate itself is stiff enough to resist rotation and bending from the diaphragm, most of the out-of-plane distortions (perpendicular to the web) concentrate in the local region of the web above the upper end of the connection plate. Fatigue cracks develop in this region as a result of the web plate bending. The cracks are usually horizontal along the web-to-flange weld, and also propagate as an upside down U along the upper ends of the fillet welds of the connection plate. Detection of cracks of such length is not difficult. Knowing that unattached ends of diaphragm connection plates are likely locations of fatigue cracks increases the certainty of early detection of these cracks (see Figures 8.2.27 and 8.2.28).

SECTION 8: Inspection and Evaluation of Common Steel Superstructures  
TOPIC 8.2: Rolled Steel Multi-beams and Fabricated Steel Multi-girders

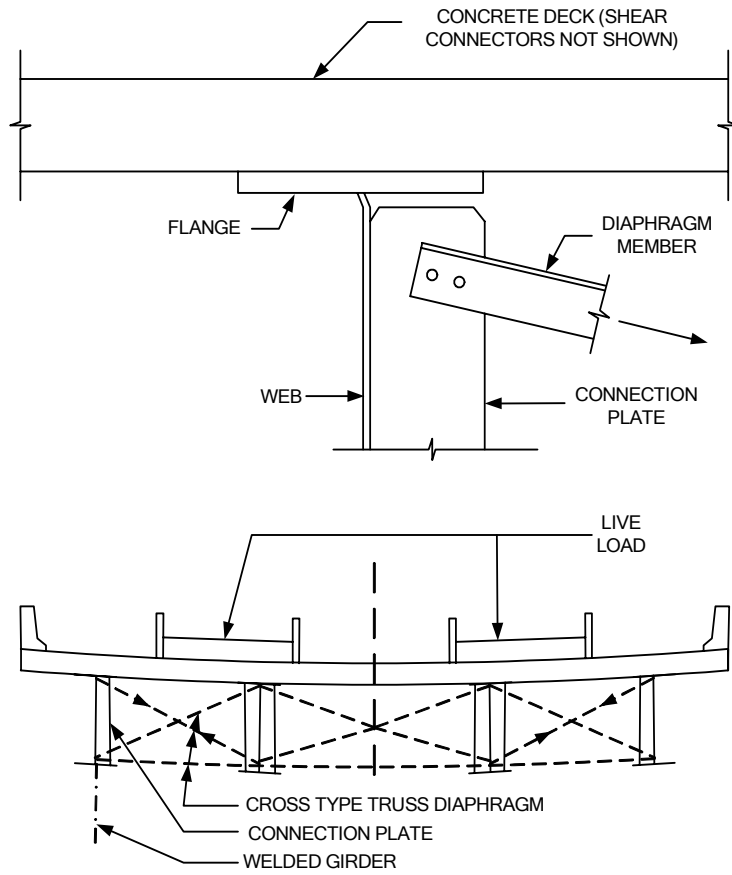

**Figure 8.2.27** Out-of-plane Distortion in Web Gap at Diaphragm Connections



**Figure 8.2.28** Web Crack due to Out-of-plane Distortion at Top Flange

Connection plate at bottom flange - At the lower end of diaphragm connection plates which are not welded to the tension flange of girders, the condition of local out-of-plane distortion and bending of the web plate usually is less severe. This is because the tension flange is not restrained from lateral movement, which is sufficient to reduce the web plate bending. However, if the bottom flange is restrained from lateral deflection (e.g., at bearings), fatigue cracks will develop along the web to flange weld (see Figure 8.2.29).



**Figure 8.2.29** Web Crack due to Out-of-plane Distortion at Bottom Flange

Skewed bridges - Another location where fatigue cracking has developed at the unattached lower end of diaphragm connection plate is in skewed bridges. Most of these diaphragms are perpendicular to the girders and thus are subjected to large differential vertical deflections which in turn cause out-of-plane distortion at the lower end of the diaphragm connection plate. If the girder flange is relatively thick and stiff against lateral displacement, most of the deflection is accommodated by bending of the web plate within the gap between the flange and the end of the connection plate welds. Fatigue cracks may initiate.

The crack starts at the bottom of the vertical plate, grows upward in a U-shape and then propagates horizontally into the web. "Bleeding" of the crack indicates that there is relative movement of the crack surface, and moisture will combine with the oxide to streak down the surface. Severely skewed bridges with relatively heavy flanges should have the lower ends of diaphragm connection plates inspected frequently, if these connection plates are not attached to the bottom flange.

#### Ends of Diaphragm Connection Plates in Girder Bridges

Current design specifications and standards call for diaphragm connection plates to be positively attached to the girder flanges in order to resist the forces and deflections induced by the diaphragm members. If the attachment or detail

condition is not adequate, fatigue cracks can develop at the end connection. One of these conditions is insufficient fillet weld between the end of a connection plate and the girder flange. This weld must be able to endure the lateral forces from the diaphragm components. If the fillet weld cracks, it will eventually sever the diaphragm connection plate from the flange. A horizontal fatigue crack can then develop in the web plate because of the out-of-plane distortion.

Sometimes, the diaphragm components are connected to gusset plates, which are welded to the vertical connection plates. The ends of the groove weld between the gusset plate and the connection plate have an abrupt change in plate geometry with re-entrant corners at the top of the connection plates. Fatigue cracks have developed in this region.

Unless these fatigue cracks are accompanied by movement and by oxide powder, their existence may not be obvious. Careful inspection from both sides of the diaphragm is necessary.

#### Lateral Gussets on Plate Girder Webs at Connections

Many fatigue cracks resulting from out-of-plane distortion of girder webs have been detected in web plates at the junction of lateral bracing gussets and diaphragm connection plates. The unequal lateral forces from the bracing members introduce lateral deflection and twisting of the junction in the direction perpendicular to the web. If the gusset plate is not attached to the vertical connection plate, the web plate in the small horizontal gap between the gusset plate and the connection plate is subjected to relative out-of-plane distortion and development of fatigue cracking. The vertical deflection of the lateral bracing causes stresses in the lateral bracing gusset plates. The welds connecting the lateral bracing gusset plates to the girder web may experience fatigue cracking.

## 8.2.5

### Evaluation

State and federal rating guideline systems have been developed to aid in the inspection of steel superstructures. The two major rating guideline systems currently in use are the FHWA's *Recording and Coding Guide for the Structural Inventory and Appraisal of the Nation's Bridges* used for the National Bridge Inventory (NBI) component rating method and the AASHTO element level condition state assessment method.

#### NBI Rating Guidelines

Using the NBI rating guidelines, a 1-digit code on the Federal Structure Inventory and Appraisal (SI&A) sheet indicates the condition of the superstructure. Rating codes range from 9 to 0 where 9 is the best rating possible. See Topic 4.2 (Item 59) for additional details about NBI Rating Guidelines.

The previous inspection data should be considered along with current inspection findings to determine the correct rating.

SECTION 8: Inspection and Evaluation of Common Steel Superstructures  
TOPIC 8.2: Rolled Steel Multi-beams and Fabricated Steel Multi-girders

**Element Level Condition State Assessment** In an element level condition state assessment of a steel girder bridge, the AASHTO CoRe element is:

<u>Element No.</u>	<u>Description</u>
106	Unpainted Steel Girder/beam
107	Painted Steel Girder/beam

The unit quantity for the girder/beam is meters or feet, and the total length must be distributed among the four available condition states for unpainted and five available condition states for painted structures depending on the extent and severity of deterioration. In both cases, Condition state 1 is the best possible rating. See the *AASHTO Guide for Commonly Recognized (CoRe) Structural Elements* for condition state descriptions.

A Smart Flag is used when a specific condition exists, which is not described in the CoRe element condition state. The severity of the damage is captured by coding the appropriate Smart Flag condition state. The Smart Flag quantities are measured as each, with only one each of any given Smart Flag per bridge.

For damage due to fatigue, the “Steel Fatigue” Smart Flag, Element No. 356, can be used and one of the three condition states assigned. For rusting between riveted members, the “Pack Rust” Smart Flag, Element No. 357, can be used and one of the four condition states assigned. For damage due to traffic impact, the “Traffic Impact” Smart Flag, Element No. 362, can be used and one of the three condition states assigned. For girders/beams with section loss due to corrosion, the “Section Loss” Smart Flag, Element No. 363, can be used and one of the four condition states assigned.